

REVIEW

Integrated Akt/PKB Signaling in Immunomodulation and Its Potential Role in Cancer Immunotherapy

Gongda Xue, Alfred Zippelius*, Andreas Wicki*, Mario Mandalà, Fengyuan Tang, Daniela Massi, Brian A. Hemmings

Affiliations of authors: Department of Mechanisms of Cancer, Friedrich Miescher Institute for Biomedical Research, 4058 Basel, Switzerland (GX, FT, BAH); Department of Biomedicine, University Hospital Basel, 4031 Basel, Switzerland (GX, AZ, AW); Unit of Clinical and Translational Research, Department of Oncology and Hematology, Papa Giovanni XXIII Hospital, 24100 Bergamo, Italy (MM); Division of Pathological Anatomy, Department of Surgery and Translational Medicine, University of Florence, 50134 Florence, Italy (DM).

* Authors contributed equally to this work.

Correspondence to: Gongda Xue, PhD, Department of Biomedicine, University Hospital Basel, 4031 Basel, Switzerland (e-mail: gongda.xue@unibas.ch).

Abstract

T cell development and maturation involve a variety of defined and coordinated developmental stages under the control of a variety of signaling networks. They function as the major mediator in cell-based immunity that defends against pathogen infections and executes immune surveillance against tumor cells. Protein kinase B (PKB, also called Akt) is central to multiple signaling pathways and transduces extracellular signals to dictate cellular responses towards proliferation, migration, anti-apoptosis, and maintenance of metabolic homeostasis. Although the prosurvival function of PKB was thought to be responsible for most of the functions regulated by PKB, emerging evidence has started to dissect its role in immunomodulation. More importantly, hyperactivation of PKB in cancer stroma frequently occurs in patients treated clinically with targeted cancer therapies, where it acts as a key mediator involved in the trapping of host immune cells in the vicinity of tumors, which supports cancer cell invasion and the escape of cancer cells from host immune surveillance. Encouragingly, recent studies have shown that inhibition of PKB improves the recognition of cancer cells by the host immune system, indicating a potential clinical strategy to rekindle the suppressed host immune response through the specific targeting of PKB. In this review, we explore how PKB signaling contributes to T cell development and cellular immune responses and discuss the mechanistic roles that PKB plays in the creation of immunosuppressive conditions and the escaping of immune recognition in the microenvironment of cancer.

Introduction to PKB

PKB is a serine/threonine kinase of the AGC protein kinase subfamily (1). It comprises three highly sequence-identical isoforms in mammals, PKB α , PKB β , and PKB γ , that are ubiquitously expressed in all cell types with slight differences in tissue distribution (2). In response to a variety of stimuli including growth factors and hormones that trigger rapid activation of lipid kinase phosphoinositide 3 kinase (PI3K), the secondary messenger molecule Phosphatidylinositol (3,4,5)-trisphosphate (PIP3) is generated (3), which in turn recruits PKB to the plasma membrane where it is phospho-activated by phosphoinositide-dependent

kinase-1 (PDK1) (on Thr308). Maximal kinase activity of PKB is achieved through mammalian target of rapamycin complex 2 (mTORC2)- or DNA-dependent protein kinase (DNAPK)-mediated phosphorylation on Ser473 (1,4). Therefore, PKB is a direct functional downstream target of PI3K under the control of PDK1 and mTORC2 or DNAPK (Figure 1). Genetic studies in knockout mice have indicated a primary function of PKB as a promoter of cell proliferation and survival (5,6). Consistent with its physiological role in development, PKB has been found to be hyperactivated in many types of cancer. Inhibition of PKB activity not

Received: January 21, 2015; Revised: March 1, 2015; Accepted: May 22, 2015

© The Author 2015. Published by Oxford University Press. All rights reserved. For Permissions, please e-mail: journals.permissions@oup.com.

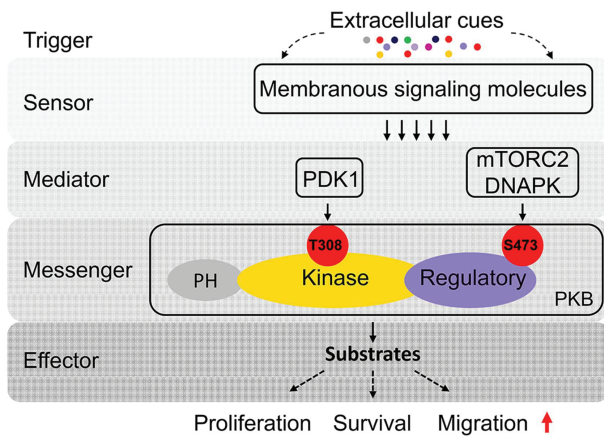

Figure 1. Molecular mechanism of protein kinase B (PKB) signaling transduction. Extracellular signals such as chemokines, cytokines, and growth factors bind to their membrane receptors and activate corresponding axes. Intracellular mediators such as PDK1 and mTORC2 kinases are simultaneously activated and transduce messages to the central hub PKB. As a “tertiary” messenger, PKB directs cell fate through phospho-regulation of its substrates, most of which transcriptionally control cell proliferation, survival and migration. DNAPK = DNA-dependent protein kinase; mTORC2 = mammalian target of rapamycin complex 2; PDK1 = phosphoinositide-dependent kinase 1.

only attenuates tumor growth (7,8) but also local invasion and metastasis (9) resulting from crosstalk with other oncogenic signaling such as mitogen-activated protein kinase (MAPK) (10), transforming growth factor- β (TGF- β) (11,12), vascular endothelial growth factor (VEGFR) (13), and (ephrin) Eph (14). In this regard, PKB is an attractive target for cancer therapies and several promising inhibitors of PKB are currently being validated in clinical trials including MK-2206 (15,16), Perifosin (17–21), and RX-0201 (22).

PKB-Regulated T Cell Development

PKB at the β -Selection Checkpoint

T cell development can broadly be split into four steps: 1) common lymphoid progenitors (CLPs) derived from bone-marrow hematopoietic cells migrate to the thymus where they act as early T cell progenitors (ETPs); 2) ETPs then autonomously undergo four stages of transition from double-negative expression of CD4/CD8 (DN, CD4⁻CD8⁻) to double-positive expression (DP, CD4⁺CD8⁺). This represents the maturation stage of thymocytes, and these cells express low levels of pre-T cell receptor (TCR); 3) mature “single-positive” cells are then selected by MHC-induced positive and negative selection and 4) subsequently emigrate to the periphery in response to sphingosine-1-phosphate (S1P) stimulation for final maturation (Figure 2).

At the first key checkpoint (the transition from DN3 to DN4 cells before CD4 and CD8 are simultaneously expressed), ETPs undergo rearrangement of the β -chain of the pre-TCR (23,24), a fundamental event to prime the structural properties for pairing with pre-TCR α -chain on the surface of the thymocytes, a process defined as β -selection. A number of early studies showed that Notch activity plays a crucial role in determining which thymocytes with functional pre-TCRs enter into the DN4 stage (25–27). Importantly, this prosurvival effect of Notch signaling is abolished upon PI3K/PKB inhibition, and expression of constitutively active PKB efficiently rescues Notch loss-induced apoptosis by bypassing PI3K signaling, indicating a stringent role for PKB in the control of pre-T cell survival (28). A recent study

uncovered that Hes1, the downstream target of Notch signaling, mediates elevated PKB signaling through targeting phosphatase and tensin homolog (PTEN) (29). Similarly, DN3 cells with PKB depletion undergo apoptosis in response to pre-TCR stimulation (30). In fact, downregulation of PKB activity leads to substantial developmental blockage at the DN3 stage, indicating the failure of differentiation driven by Notch signaling (31). In line with the role of PKB in promoting β -selection, some PKB targets such as Glycogen synthase kinase 3 (GSK3)/T-cell factor 1 (TCF-1)/ β -catenin (32–34) and cAMP response element-binding protein (CREB) (35) were also shown to participate in signaling regulation at this checkpoint. This raises the question of whether these events are also dependent on PKB activity, which needs future investigation.

PKB Activation During Thymic Selection and Maturation

When thymocytes pass β -selection and enter the DP (CD4⁺CD8⁺) stage, characterized by low-level expression of pre-TCR, the cells need to vigorously proliferate. Previous studies showed that this was enabled by activated PKB that upregulated levels of Bcl-XL, a member of the anti-apoptotic Bcl-2 family (36,37). DP thymocytes that moderately recognize self-peptide-major histocompatibility complex (MHC) complexes survive and are induced to differentiate (positive selection), whereas those that recognize self-peptide-MHC complexes with high affinity/avidity are induced toward cell death (negative selection) to eliminate potentially toxic T cells. These two programs of thymic selection are coupled with TCR-regulated cell survival through PKB, which selectively modulates an apoptotic effector downstream of TCR signaling, the orphan nuclear receptor Nur77, and thus drives naive T cell maturation (38).

Following functional postselection of thymocytes expressing either CD4 or CD8 protein, these single-positive (SP, CD4⁺CD8⁻ or CD4⁻CD8⁺) thymocytes migrate to the periphery where they further develop into different functional T cell populations. S1P signaling is required to ensure that only mature SP thymocytes are permitted to enter the periphery. Loss of S1P receptor 1 (S1P₁) expression on mature SP thymocytes blocks the thymic egress of these cells because of inhibition of the chemotactic activity mediated by S1P/S1P₁ signaling (39). Interestingly, PKB-dependent phosphorylation of S1P₁ is required for S1P₁-mediated chemotaxis (40). In addition, S1P₁ expression is transcriptionally regulated by Krüppel-like factor 2 (KLF2) which is also required for cell trafficking (41) and whose expression is stringently controlled by forkhead box O (FoxO) family member FoxO1, a well-characterized phospho-target of PKB (42,43). Therefore, PKB/FoxO1/KLF2 signaling is likely central in determining a complete mature state of the thymocytes that egress from the thymus at the late stage of T cell development. C-C chemokine receptor 7 (CCR7) and CCR9 were also shown to determine the fate of ETPs homing to thymus (44,45); however, it is not clear whether this early step in T cell development is also regulated by PKB/FoxO1 signaling.

Owing to the global importance of PKB in supporting cell proliferation and survival and overcoming apoptosis, it is not surprising that PKB acts as a gatekeeper to secure the smooth transition through these developmental checkpoints. This role of PKB is unlikely to be restricted only to T cell development. A few studies have already shown the similar functions for PKB in other types of immune cells such as B cells (46–48), dendritic cells (49–52), macrophages (53,54), and neutrophils (55). Thus, PKB is crucial in regulating immune cell development.

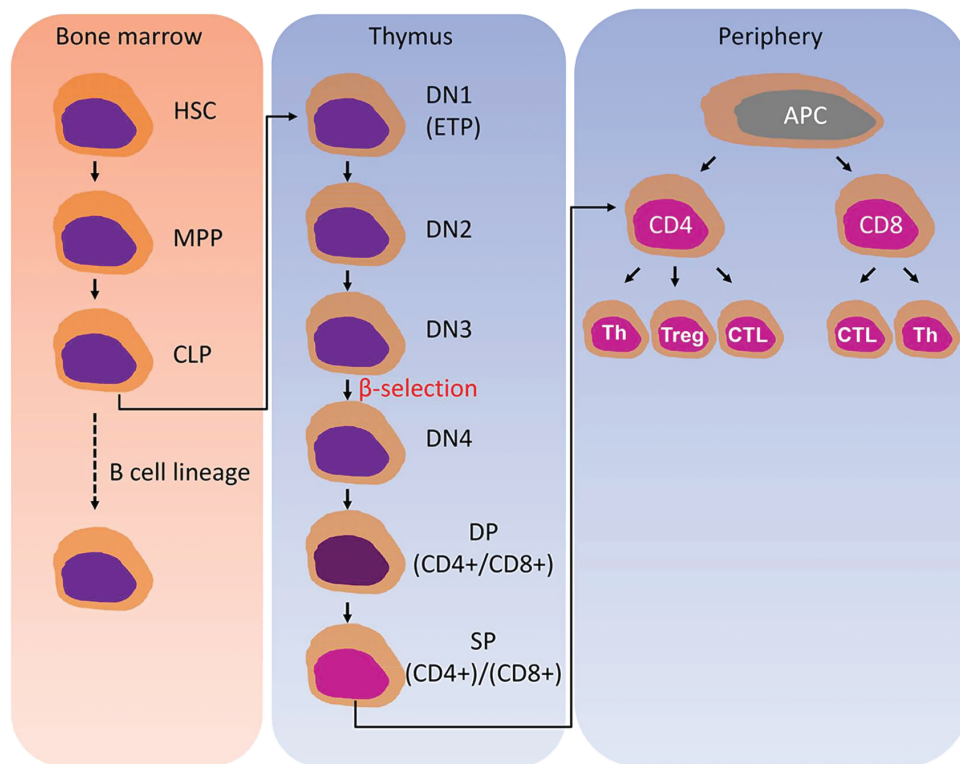

Figure 2. Key steps and checkpoints during T cell development. APC = antigen-presenting cell; CLP = common lymphoid progenitor; CTL = cytotoxic T lymphocytes; DN = double negative; DP = double positive; HSC = hematopoietic stem cell; MPP = multipotent progenitor; SP = single positive; Th = helper T cells; Treg = regulatory T cells.

PKB-Dependent Regulation of T Cell Functionality

The Impact of PKB on CD8⁺ T Cell Metabolism and Response

mTOR-directed involvement of PI3K/PKB signal transduction has been shown to be pivotal to glucose metabolism (56). Upon stimulation, the fate of CD8⁺ T cells (effector or memory) is determined by cytokines, particularly interleukin 2 (IL-2). Previously it was shown that stimulation of T cells with anti-CD3 and anti-CD28 induces glucose uptake and aerobic glycolysis (the Warburg effect) in a PKB-dependent but IL-2-independent manner (57). In primary CD8⁺ T cells with depleted TCR signaling, attenuated glucose metabolism through reduced glycolysis is triggered by decreased expression of glucose transporter 1 (Glut1) (58), whose expression level and stabilized membrane translocation require PKB activity (59,60). PKB-regulated glucose metabolism was further supported by follow-up studies that showed that constitutive activation of PKB may override the influence of cytokine stimulation on Glut1 activation (61,62). Consistently, upon reactivation of memory CD8⁺ T cells, the metabolic switch from basal fatty acid oxidation and mitochondrial oxidative phosphorylation to aerobic glycolysis and lipid synthesis, needed for rapid acquisition of effector functionality such as the production of IFN γ , is regulated by PKB rather than mTORC1 (63). Thus, PKB is a crucial signaling cascade responsible for elevated metabolic rate in T cells.

The activities of many transcriptional factors that are crucial for determining cell fate and behavior are post-translationally modulated by PKB (9). A recent study showed that inhibition of PKB decreases mRNA levels of several key molecules responsible

for T cell effector functions, including granzymes, perforin, Fas ligand, IFN γ , and cytokine receptors such as IL-12R, indicating that TCR-mediated transcriptional programs that determine effector or memory cell differentiation are strictly dependent on PKB (64). This seems to be in agreement with a recent study showing that conversion of CD8⁺ T cells from memory to effector state requires PKB activation (63).

CD8⁺ T cells responding to stimuli follow three distinct phases: clonal expansion, contraction, and establishment of memory. As the metabolic and survival regulator of T cells, it is not surprising that PKB dictates the magnitude of CD8⁺ T cell memory through controlling dynamic alterations in proliferation and apoptotic rates via its downstream mediator FoxO family members (65). Once the infecting pathogens are cleared, autonomous apoptosis occurs in the majority of pathogen-specific effector CD8⁺ T cells through the PKB/FoxO axis, whereas a small percentage will develop into memory CD8⁺ T cells for rapid response to secondary stimulation in the future (66). This is similar to the role of PKB during thymic selection, where TCR priming leads to massive cell death in absence of PKB signaling. Taken together, these data support a concept that PKB is an essential regulator along the immunometabolic signaling pathway in T cells, but with differentially defined functional specificity in different T cell subpopulations in response to diverse stimuli.

PKB Regulates CD4⁺ T Cell Differentiation

Peripheral naïve CD4⁺ T cells mature and differentiate in response to antigenic stimulation into distinct functional subsets with specific roles in the regulation of the immune response. The fate of the cells is determined by individual stimuli, most of which

are from interleukin family members. Each specialized CD4⁺ T cell lineage exhibits functionally dominant transcriptional programs driven by unique pools of transcription factors such as T-box binding protein (T-bet), GATA family member GATA3, fork-head box P3 (FoxP3), and RAR-related orphan receptor gamma 3 (ROR γ 3), representing T helper cell 1 (Th1), Th2, regulatory T cell (Treg), and Th17 lineages, respectively (Figure 3A). PKB activity is tightly associated with the differentiation state of CD4⁺ T cells, and numerous studies have shown that it contributes substantially to the regulation of signaling events at transcriptional and translational levels, under both physiological and pathological settings (67–69). In the scenario of global control, PKB-mediated direct phosphorylation of FoxO1 and FoxO3a leads to cytoplasmic sequestration, thus inhibiting their DNA binding activity (70). In T cells, FoxO1 and FoxO3a transcriptionally activate T-bet (71,72) and FoxP3 (73–76), which inversely associate with PKB activity.

In most cases, it is the expression ratio among the transcription factors, rather than the overexpression or suppression of a single protein, that determines the differentiation fate of CD4⁺ T cell lineage. This obviously raises the question of how this balance of transcription factors is maintained. Recent studies have started to uncover the potential mechanisms. Under inflammatory conditions, elevated TGF- β signaling promotes Treg cell functionality through promotion of FoxP3 but restrains Th17 phenotype by decreasing levels of RAR-related orphan receptor gamma t (ROR γ t) (77). Opposing expression patterns of FoxP3 and ROR γ t in the same cell population are possible, at least partly, because of a physical inhibitory interaction (78,79). When extracellular conditions favor a transition to Th17 differentiation, IL-6 may counteract FoxP3-mediated inhibition of ROR γ t. Interestingly, a recent study also showed that PKB/mTORC1-mediated activation of ribosomal protein S6 kinase 2 (S6K2) promotes ROR γ t nuclear translocation through direct coupling (80). Moreover, to enhance the maintenance of Treg differentiation, expression of GATA3 maintains high levels of

FoxP3 but inhibits T-bet and ROR γ t through as yet undefined mechanisms (81). By contrast, to maintain a Th1 phenotype the functionality of GATA3 can be physically repressed by T-bet by directly interfering with its DNA binding capacity (82). While it is not yet clear whether PKB can directly affect the function of GATA3, studies have shown that PKB can directly phosphorylate and functionally influence GATA1 (83) and GATA2 (84). Given the high degree of sequence similarity in the DNA-binding domain adjacent to the distal zinc-finger motif (85) among GATA family members (Figure 3B), it would be interesting to investigate if PKB can influence Th2 cell differentiation directly through GATA3 by bypassing FoxO. Therefore, under the global surveillance of PKB/FoxO signaling axis, a precisely regulated interplay between the transcriptional signature molecules seems to be the dominating factor that determines the differentiation of CD4⁺ T cell lineages (Figure 3C).

The Role of PKB in Escaping Immunosurveillance in Cancer

PKB Controls the Expression of Chemokines

The mTOR/PI3K/PKB signaling pathway is highly deregulated in human diseases, such as cancer, which require an aberrant demand of metabolic rate. The surrounding environment of tumors, the cancer stroma, is the fundamental resource for nutrient supply to cancer cells. Cancer stroma consists of a variety of cell types, including cancer-associated fibroblasts (CAF), endothelial cells, myeloid cells, lymphocytes, and pericytes (86), many of which are actively recruited to the cancer environment and utilized by cancer cells to satisfy the increased metabolic demand. Consistent with the pivotal role of PKB during immune cell development, extensive studies have revealed that PKB stimulates aerobic glycolysis in many types of cancer cells (87–90) (comprehensively reviewed by Ward et al. [91]). Intriguingly, PKB-regulated cancer cell metabolism can be further enhanced

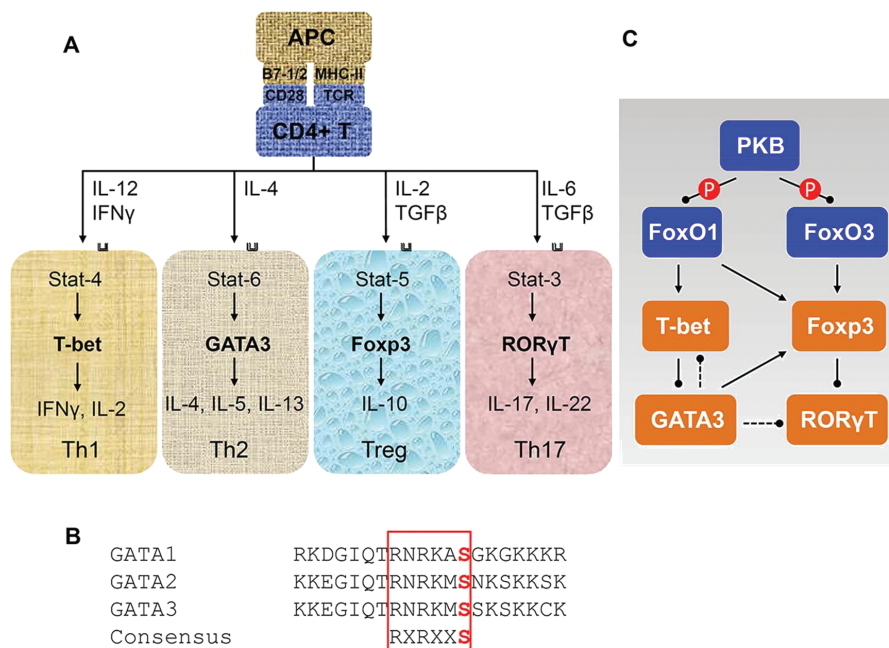

Figure 3. Regulation of CD4⁺ T cell differentiation. **A)** CD4⁺ T cells are differentiated into four main lineages with distinct transcriptional programs in response to stimulation of different chemokines. **B)** Sequence alignment of human GATA family members. **C)** Protein kinase B (PKB)-mediated regulation of the transcriptional determinants towards terminal differentiation of CD4⁺ T cells. APC = antigen presenting cell; MHC = major histocompatibility complex; TCR = T cell receptor.

when cancer cells encounter disturbing situations such as a stiffened extracellular matrix (92), indicating that cancer cells are capable of autonomous adaption to their niche environment through PKB-promoted metabolism.

CAFs and endothelial cells are responsible for tumor initiation and establishment of tumor vascular network essential for local invasiveness and nutrient/oxygen supply (93,94). It is now becoming evident that the immune cells in the vicinity of the cancer niche also markedly impact aspects of cancer biology, including tumor cell metastasis to distant organs, cancer angiogenesis, cancer immune regulation, and overcoming metabolic stress (95). Directional trafficking of immune cells to the cancer niche is a chemotactic process triggered mainly by chemokines secreted from cancer cells in a gradient-dependent manner (96), which results in the entire tumor niche acting as a core regulator that modulates survival, invasion, and immune-suppression (97).

Although PI3K is a key regulator of chemoattractants (such as PIP3) (98), PKB signaling can potentially control cell migration in different settings (9). Inflammatory conditions in the vicinity of developing tumors, particularly chronic inflammation, are positively associated with tumor progression. Pivotal pathways that regulate tumor-associated inflammation, such as the tumor necrosis factor (TNF)/I κ B kinase (IKK)/nuclear factor κ B (NF- κ B) axis, can be induced and enhanced through tumor-expressing molecules, whose activation, in turn, promotes malignant transformation of tumor cells. Upregulation of tumor-associated inflammatory factors is often orchestrated by transcriptional events driven by NF- κ B signaling, which is tightly under the control of crosstalk between PKB and the IKK signalosome (99–102). By pairing to CCR6, C-C chemokine ligand 20 (CCL20) has been shown to be a key mediator in many inflammatory diseases including cancer (103–105). Migration of Th17 cells towards developing tumors is driven by CCL20, and this requires PKB activation. Mechanistically, the transcriptional regulation of CCL20 is mediated through nuclear translocation and activation of NF- κ B (106–108), a transcriptional complex negatively regulated by its endogenous inhibitor I κ B, which is degraded by PKB-mediated phosphorylation. Similarly, PKB-mediated activation of NF- κ B regulates many chemokines during chemotactic

migration of cells such as dendritic cells via CCL19 (109); CTL cells, Th2 cells, and macrophages via CCL5 (110); and Treg cells via CCL17 and CCL22 (111,112). The chemokine-mediated immune cell migration to the cancer niche is summarized in Figure 4. Undoubtedly, most of these chemoattractants are also expressed by different subsets of immune cells that cooperatively stimulate local inflammation in cancer stroma. It is also known that PKB-regulated NF- κ B transcriptionally activates Snail, an epithelial-mesenchymal transition inducer that promotes cell migration in a context-dependent manner (113,114). Snail is capable of upregulating pro-inflammatory cytokines such as IL-1, IL-6, and IL-8, which enhance the chemotactic migration of both immune cells and metastatic cancer cells (115). Moreover, activation of Snail also elevates levels of CCL2 in melanoma (116). PKB activates Snail by phospho-inhibition of GSK3, an upstream inhibitory kinase that prevents the nuclear translocation of Snail (117).

Likewise, the expression of chemokine receptors may also be controlled by PKB. For example, in prostate cancer with PTEN loss, ablation of PKB results in a sizable decrease in C-X-C chemokine receptor 4 (CXCR4) at both the transcriptional and translational levels, which consequently inhibits metastatic spread by disrupting the CCL12/CXCR4 network (118). As well as regulating chemokines, NF- κ B is also thought to regulate chemokine receptors such as CCR5 and CCR7 (119). Activation of chemokine and cytokine signaling can mediate a feed-forward signaling loop that enhances intracellular PKB activity, a mechanism that has been widely demonstrated in the signaling network of receptor tyrosine kinase/PI3K/PKB in cancer. In a xenograft model of breast cancer, CCL5 secreted from mesenchymal stem cells activated PKB signaling in circulating tumor cells to promote extravasation from the circulation and colonization at distal organs (120). Therefore, PI3K/PKB activation and upregulation of inflammatory chemokines and receptors can reciprocally control cell-cell communication in the cancer environment through modulation of chemotactic migration. In fact, the functional interaction between PKB and I κ B/NF- κ B has been shown to create a protumoral microenvironment at inflammatory sites where particularly chronic inflammation persistently occurs (121). The resulting inflammatory responses

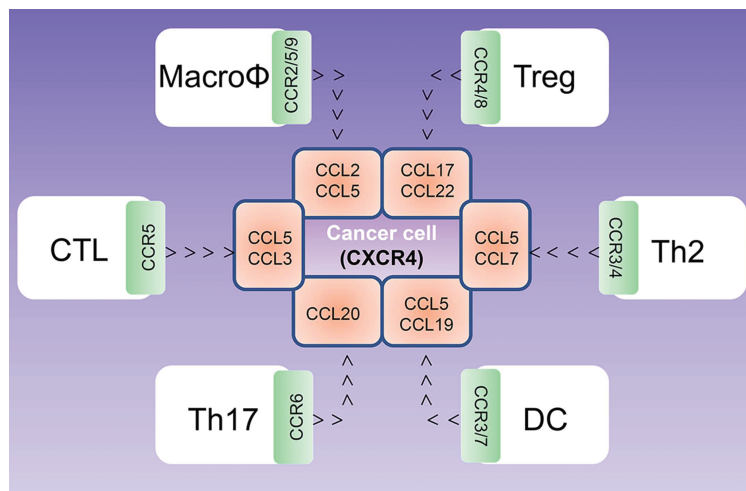

Figure 4. Chemokine-mediated immune cell trafficking to tumor vicinity. Individual chemokines expressed by cancer cells are highlighted in pink boxes, and the corresponding chemokine receptors expressed by immune cells are highlighted in the green boxes. Note: Many chemokines are also expressed by different immune cells peritumorally or intratumorally to regulate local inflammation and cell-cell interaction. Because of its complex nature, this aspect is not reflected in the simplified cartoon. Open arrows indicate migratory direction. CCL = C-C chemokine ligand; CCR = C-C chemokine receptor; CTL = cytotoxic T lymphocytes; CXCR = C-X-C chemokine receptor; DC = dendritic cells; MacroΦ = macrophage; Th = T helper cell; Treg = regulatory T cells.

can augment tumor cell growth and metastasis through a combination of accelerated cell cycle, increased genomic instability, and cytoskeleton remodeling-induced motility.

PKB Supports Tumor Cells to Escape from Immunosurveillance

For several decades, the infiltration and accumulation of immune cells in the tumor vicinity was thought to be detrimental to cancer cells. However, all types of immune cells are found in different tumors, regardless of the cancer type, origin, and residing organs. These immune cells differentially impact tumor development by mediating the interactions between cancer cells and the environment. Clinical trial data has shown that infiltration of CD8⁺ T cells, natural killer (NK) cells, and Th1 cells within tumors is associated with a good prognosis in most types of cancer, whereas infiltration of Th2, Treg, Th17 cells, macrophages, and neutrophils is associated with poor prognosis (122–126). This implies that certain immune cell types may have a tumor-promoting role during cancer development. Indeed, tumor cells that survive intrinsic and/or extrinsic stress, including host immune defense, neglect the immune detection and gain tolerance (127).

Despite the impacts of myeloid-derived suppressor cells (MDSC) and Treg-mediated T cell anergy (128,129), several mechanisms for the escape from host immunosurveillance by cancer cells have been suggested, including impaired antigen-presenting activity, unfavorable cytokine and chemokine secretion, and direct suppression of immune cell function by interaction of inhibitory molecules on cancer cell surface with immune cell surface markers (130,131). These immune resistance mechanisms may arise from local immunological stress, whereby selected cancer cells that survive the innate immune response undergo stress-induced genetic or epigenetic modifications to adapt to the tumor microenvironment and evade immune detection. This organized process, also called cancer immunoeediting (132), mechanistically mimics the clonal evolution of cancer cells that underlies the acquisition of resistance to therapeutic drugs, which typically results in more aggressive tumors. Thus, it is evident that the inflammatory factors expressed by both immune cells and tumor cells in a PKB-regulated manner, can contribute to create immunosuppressive conditions.

Cell-cell interaction-triggered T cell dysfunction is mainly mediated through inhibitory molecular pairing between programmed death ligands 1 and 2 (PD-L1/2) (133). These members of the B7 protein family are expressed on the surface of infiltrating cells and cancer cells, and their receptor, programmed death 1 (PD-1), is expressed on the surface of activated T cells, macrophages, dendritic cells, B cells, and NK cells (134). Under physiological conditions, when PD-1 binds to their ligands, negative signals are delivered into the T cells that attenuate their activities by inhibiting TCR-mediated proliferation to prevent tissue damage from unfavorable immune responses (135). This mechanism is appropriated by cancer cells to directly induce T cell apoptosis through a similar interaction. Interestingly, expression of PD-L1 in tumor cells is tightly associated, or regulated by PKB. In human gliomas, PTEN loss leads to increased immunoresistance through upregulation of PD-L1 in a PKB activation-dependent manner (136). Selective inhibition of PKB with small molecule inhibitor (Akt inhibitor III) was shown to decrease the expression level of PD-L1, which was mediated through PKB-regulated mTORC1/S6K1 signaling. This is in agreement with the finding that interferons may also activate PI3K/PKB/mTOR/S6K pathway (137), though the molecular mechanisms underlying

PD-L1 upregulation need further investigation. Similarly, this PKB-dependent PD-L1 expression pattern is also observed in colorectal cancer (138).

Further evidence for the role of PKB in regulation of PD-L1 come from the investigation of PD-L1 expression in triple-negative human breast cancer, where specifically targeting PKB activity with the pharmacological inhibitor MK-2206 was shown to substantially downregulate PD-L1 at the transcriptional level (139). Independent studies also showed a potential mechanism for PD-L1 downregulation at the translational level by PKB in both breast and prostate cancer (140), mutant BRAF-harboring melanomas (141), and pancreatic cancer (142). Clearly, the molecular mechanisms explaining how PKB mediates PD-L1 expression are the missing piece of the puzzle. This links to an even more complex situation in which each PKB isoform may have a different impact, as many studies have shown opposing roles of PKB isoforms in driving tumor metastasis in different types of cancer (9). Nonetheless, the emerging data clearly shows that PKB actively participates in tumor cell-mediated immunosuppression, at least through two distinct paths via promoting chemokine/cytokine expression and upregulating PD-L1 expression. Therefore, targeting the PKB signaling node may enable reviving of the host immune response in clinical cancer therapy.

T Cell Functionality Upon PKB Inhibition in the Cancer Niche

Despite the robust inhibitory effect on cancer cell proliferation and glucose uptake, evidence from recent studies also suggested that inhibition of PKB restored and enhanced physiological functionalities of T cells in the tumor microenvironment. In a mouse model of adoptive cell therapy, pharmacological inhibition of PKB with an allosteric inhibitor (AKT inhibitor VIII) reprogrammed the transcriptional events in CD8⁺ tumor-infiltrating lymphocytes (TIL) into phenotypic memory cells (143). In addition, this phenotype was coupled with improved survival of transferred antitumor TIL in vivo and an enhanced antitumor effect in the mouse model. This in vivo observation was further supported in a grafted myeloma mouse model, in which inhibition of PKB with the same inhibitor blocked the differentiation of CD8⁺ T cells, improved the expansion of CD8⁺ T cells, and was associated with superior antitumor effects in the mice (144). Moreover, inhibition of the PKB pathway with MK-2206 selectively suppressed Treg proliferation and enhanced the antitumor effect of a tumor-specific vaccine in a mouse model (145). Thus, these findings further support the concept that targeting PKB enables tumor-specific lymphocytes to exert antitumor immunity in immunotherapy for advanced cancer.

Conclusions and Perspectives

Emerging evidence highlights the importance of the tumor microenvironment as a critical regulator that determines the outcome of clinic cancer therapy. This impact is fundamentally because of the complex network of cell-cell interactions between tumor cells, immune cells, and the extracellular matrix. Therapeutic strategies that block the intercellular communication of this network have shown promising clinical benefit to the patients, and cancer immunotherapy strategies aimed at reviving functional immunosurveillance, in particular in combination with other targeted therapies, have become an effective approach in cancer clinic. For example, recent clinical

studies with PD-1- and PD-L1-blocking antibodies highlight the substantial therapeutic strategy in cancer patients with incurable tumors or relapsed tumors post-therapy (146,147). In addition, blocking CCL22 inhibits the trafficking of CCR4-expressing Treg cells to the metastatic lesion (148). Targeting tumorigenic inflammation by inhibition of CCL2 restrains CCR2-expressing immune cells, such as monocytes in bone marrow (149), which decreased the inflammatory risk from recruited tumor-associated macrophages (150) and led to suppression of metastasis in syngeneic mouse models of metastatic breast cancer.

Hyperactivation of PKB may represent a fundamental hallmark of cancer that contributes to resistance to both chemotherapy and radiotherapy (151,152). As described above, CCL22 is under transcriptional regulation of NK- κ B, which is activated by PKB-mediated degradation of I κ B. CCL2 synthesis is regulated by the Snail transcription factor, which is negatively controlled by GSK3, a direct substrate of PKB. Thus, downregulation of PKB activity can theoretically interfere with the CCL22/CCR4 and CCL2/CCR2 axes to block tumor-directed trafficking of immunosuppressive Treg and monocytes. The mechanisms of PKB-promoted immune evasion of cancer cells have been demonstrated by increased resistance to CD8⁺ T cell-mediated apoptosis (145,153,154), overriding death receptor signaling (155), strengthening energetic metabolism (156), and enforcing the functionality of immunosuppressive Treg cells (157,158). Therefore, inhibition of PI3K/PKB can principally suppress the tumor-driven immunosuppressive effect through remodeling of the entire tumor microenvironment.

Current cancer therapeutic strategies invariably induce drug resistance in the clinic. Among many potential mechanisms, the disruption of negative feedback loops and compensatory activation of other oncogenic signaling pathways are two major causes. In melanoma patients bearing an activating mutation on BRAF (V600E), inhibition of mutant BRAF with vemurafenib or dabrafenib dramatically reduces MAPK activity and improves median response duration (159). Vemurafenib therapy not only inhibits tumor growth through tumor intrinsic mechanisms but also decreases the population of immunosuppressive myeloid derived suppressor cells (MDSCs) (160) and increases levels of tumor infiltration of CD8⁺ T cells (161). However, this immunoreponsive phenotype is diminished at the time of tumor reprogression, and a comparative study implies that the intratumoral T cell infiltration is dependent on tumor sensitivity to vemurafenib (162). Importantly, at this resistance developing stage, inhibition of mutant BRAF spontaneously strengthens PI3K/PKB signaling through various mechanisms, as well as NF- κ B (163), which coincides with reduced recognition of melanoma cells by immune cells. Given the regulatory role of PKB in production of inflammatory factors, it is foreseeable that PKB will prove to be a contributor to immunounresponsiveness in melanomas resistant to vemurafenib therapy. Thus, a combinatory approach targeting oncogenic signaling while stimulating immune response is emerging as a more effective strategy (164).

As well as its critical role in chemotactic migration and chemokine/cytokine-mediated cell-cell interaction, PKB also participates in cellular adhesion to the extracellular matrix, which in parallel further enhances cell survival and migratory potential driven by local immune tolerance. This is largely attributable to the impacts on the activity of adhesion-associated molecules including focal adhesion kinase (165), EphA2 (14), Ron (166,167), Zyxin (168), CD34 (169), and CTNND2 (170), et al. Encouragingly, emerging data show improved antitumor response of T cells by inhibiting PKB signaling (171). Given the broad impact of the PKB cascade on many aspects during

cancer development, functional dissection of its emerging role in antagonizing immunosurveillance is likely to contribute substantially to cancer immunotherapeutic strategies.

Funding

The research project was funded by the Swiss National Science Foundation 31-130838 (to BAH and GX).

Notes

The Swiss National Science Foundation (the sponsor of the study) was not involved in the design of the study, the writing of the article, or the decision to submit the article for publication.

References

- Pearce LR, Komander D, Alessi DR. The nuts and bolts of AGC protein kinases. *Nat Rev Mol Cell Biol*. 2010;11(1):9–22.
- Fayard E, Xue G, Parcellier A, et al. Protein kinase B (PKB/Akt), a key mediator of the PI3K signaling pathway. *Curr Top Microbiol Immunol*. 2010;346:31–56.
- Engelman JA, Luo J, Cantley LC. The evolution of phosphatidylinositol 3-kinases as regulators of growth and metabolism. *Nat Rev Genet*. 2006;7(8):606–619.
- Cybulski N, Hall MN. TOR complex 2: a signaling pathway of its own. *Trends Biochem Sci*. 2009;34(12):620–627.
- Dummler B, Hemmings BA. Physiological roles of PKB/Akt isoforms in development and disease. *Biochem Soc Trans*. 2007;35(Pt 2):231–235.
- Scheid MP, Woodgett JR. PKB/AKT: functional insights from genetic models. *Nat Rev Mol Cell Biol*. 2001;2(10):760–768.
- Fruman DA, Rommel C. PI3K and cancer: lessons, challenges and opportunities. *Nat Rev Drug Discov*. 2014;13(2):140–156.
- Vivanco I, Sawyers CL. The phosphatidylinositol 3-Kinase AKT pathway in human cancer. *Nat Rev Cancer*. 2002;2(7):489–501.
- Xue G, Hemmings BA. PKB/Akt-dependent regulation of cell motility. *J Natl Cancer Inst*. 2013;105(6):393–404.
- Carracedo A, Ma L, Teruya-Feldstein J, et al. Inhibition of mTORC1 leads to MAPK pathway activation through a PI3K-dependent feedback loop in human cancer. *J Clin Invest*. 2008;118(9):3065–3074.
- Xue G, Restuccia DF, Lan Q, et al. Akt/PKB-mediated phosphorylation of Twist1 promotes tumor metastasis via mediating cross-talk between PI3K/Akt and TGF-beta signaling axes. *Cancer Discov*. 2012;2(3):248–259.
- Zhang L, Zhou F, ten Dijke P. Signaling interplay between transforming growth factor-beta receptor and PI3K/AKT pathways in cancer. *Trends Biochem Sci*. 2013;38(12):612–620.
- Kitamura T, Asai N, Enomoto A, et al. Regulation of VEGF-mediated angiogenesis by the Akt/PKB substrate Girdin. *Nat Cell Biol*. 2008;10(3):329–337.
- Miao H, Li DQ, Mukherjee A, et al. EphA2 mediates ligand-dependent inhibition and ligand-independent promotion of cell migration and invasion via a reciprocal regulatory loop with Akt. *Cancer Cell*. 2009;16(1):9–20.
- Yap TA, Yan L, Patnaik A, et al. First-in-man clinical trial of the oral pan-AKT inhibitor MK-2206 in patients with advanced solid tumors. *J Clin Oncol*. 2011;29(35):4688–4695.
- Yap TA, Yan L, Patnaik A, et al. Interrogating Two Schedules of the AKT Inhibitor MK-2206 in Patients with Advanced Solid Tumors Incorporating Novel Pharmacodynamic and Functional Imaging Biomarkers. *Clin Cancer Res*. 2014;20(22):5672–5685.
- Orlowski RZ. Novel agents for multiple myeloma to overcome resistance in phase III clinical trials. *Semin Oncol*. 2013;40(5):634–651.
- Guidetti A, Carlo-Stella C, Locatelli SL, et al. Phase II Study of Perifosine and Sorafenib Dual-Targeted Therapy in Patients with Relapsed or Refractory Lymphoproliferative Diseases. *Clin Cancer Res*. 2014;20(22):5641–5651.
- Richardson PG, Wolf J, Jakubowiak A, et al. Perifosine plus bortezomib and dexamethasone in patients with relapsed/refractory multiple myeloma previously treated with bortezomib: results of a multicenter phase I/II trial. *J Clin Oncol*. 2011;29(32):4243–4249.
- Bendell JC, Nemunaitis J, Vukelja SJ, et al. Randomized placebo-controlled phase II trial of perifosine plus capecitabine as second- or third-line therapy in patients with metastatic colorectal cancer. *J Clin Oncol*. 2011;29(33):4394–4400.
- Ghobrial IM, Roccaro A, Hong F, et al. Clinical and translational studies of a phase II trial of the novel oral Akt inhibitor perifosine in relapsed or relapsed/refractory Waldenström's macroglobulinemia. *Clin Cancer Res*. 2010;16(3):1033–1041.
- Pal SK, Reckamp K, Yu H, et al. Akt inhibitors in clinical development for the treatment of cancer. *Expert Opin Investig Drugs*. 2010;19(11):1355–1366.
- Levelt CN, Carsetti R, Eichmann K. Regulation of thymocyte development through CD3. II. Expression of T cell receptor beta CD3 epsilon and matura-

- tion to the CD4+8+ stage are highly correlated in individual thymocytes. *J Exp Med.* 1993;178(6):1867–1875.
24. Levelt CN, Ehrfeld A, Eichmann K. Regulation of thymocyte development through CD3. I. Timepoint of ligation of CD3 epsilon determines clonal deletion or induction of developmental program. *J Exp Med.* 1993;177(3):707–716.
 25. Duncan AW, Rattis FM, DiMascio LN, et al. Integration of Notch and Wnt signaling in hematopoietic stem cell maintenance. *Nat Immunol.* 2005;6(3):314–322.
 26. Huang EY, Gallegos AM, Richards SM, et al. Surface expression of Notch1 on thymocytes: correlation with the double-negative to double-positive transition. *J Immunol.* 2003;171(5):2296–2304.
 27. Ciofani M, Schmitt TM, Ciofani A, et al. Obligatory role for cooperative signaling by pre-TCR and Notch during thymocyte differentiation. *J Immunol.* 2004;172(9):5230–5239.
 28. Ciofani M, Zuniga-Pflucker JC. Notch promotes survival of pre-T cells at the beta-selection checkpoint by regulating cellular metabolism. *Nat Immunol.* 2005;6(9):881–888.
 29. Wong GW, Knowles GC, Mak TW, et al. HES1 opposes a PTEN-dependent check on survival, differentiation, and proliferation of TCRbeta-selected mouse thymocytes. *Blood.* 2012;120(7):1439–1448.
 30. Juntilla MM, Wofford JA, Birnbaum MJ, et al. Akt1 and Akt2 are required for alphabeta thymocyte survival and differentiation. *Proc Natl Acad Sci U S A.* 2007;104(29):12105–12110.
 31. Mao C, Tili EG, Dose M, et al. Unequal contribution of Akt isoforms in the double-negative to double-positive thymocyte transition. *J Immunol.* 2007;178(9):5443–5453.
 32. Gounari F, Aifantis I, Khazaie K, et al. Somatic activation of beta-catenin bypasses pre-TCR signaling and TCR selection in thymocyte development. *Nat Immunol.* 2001;2(9):863–869.
 33. Xu Y, Banerjee D, Huelsken J, et al. Deletion of beta-catenin impairs T cell development. *Nat Immunol.* 2003;4(12):1177–1182.
 34. Goux D, Coudert JD, Maurice D, et al. Cooperating pre-T-cell receptor and TCF-1-dependent signals ensure thymocyte survival. *Blood.* 2005;106(5):1726–1733.
 35. Grady GC, Mason SM, Stephen J, et al. Cyclic adenosine 5'-monophosphate response element binding protein plays a central role in mediating proliferation and differentiation downstream of the pre-TCR complex in developing thymocytes. *J Immunol.* 2004;173(3):1802–1810.
 36. Jones RG, Parsons M, Bonnard M, et al. Protein kinase B regulates T lymphocyte survival, nuclear factor kappaB activation, and Bcl-X(L) levels in vivo. *J Exp Med.* 2000;191(10):1721–1734.
 37. Suzuki A, Yamaguchi MT, Ohteki T, et al. T cell-specific loss of Pten leads to defects in central and peripheral tolerance. *Immunity.* 2001;14(5):523–534.
 38. Masuyama N, Oishi K, Mori Y, et al. Akt inhibits the orphan nuclear receptor Nur77 and T-cell apoptosis. *J Biol Chem.* 2001;276(35):32799–32805.
 39. Matloubian M, Lo CG, Cinamon G, et al. Lymphocyte egress from thymus and peripheral lymphoid organs is dependent on S1P receptor 1. *Nature.* 2004;427(6972):355–360.
 40. Lee MJ, Thangada S, Paik JH, et al. Akt-mediated phosphorylation of the G protein-coupled receptor EDG-1 is required for endothelial cell chemotaxis. *Mol Cell.* 2001;8(3):693–704.
 41. Carlson CM, Endrizzi BT, Wu J, et al. Kruppel-like factor 2 regulates thymocyte and T-cell migration. *Nature.* 2006;442(7100):299–302.
 42. Rena G, Guo S, Cichy SC, et al. Phosphorylation of the transcription factor forkhead family member FKHR by protein kinase B. *J Biol Chem.* 1999;274(24):17179–17183.
 43. Ouyang W, Li MO. Foxo: in command of T lymphocyte homeostasis and tolerance. *Trends Immunol.* 2011;32(1):26–33.
 44. Zlotoff DA, Sambandam A, Logan TD, et al. CCR7 and CCR9 together recruit hematopoietic progenitors to the adult thymus. *Blood.* 2010;115(10):1897–1905.
 45. Calderon L, Boehm T. Three chemokine receptors cooperatively regulate homing of hematopoietic progenitors to the embryonic mouse thymus. *Proc Natl Acad Sci U S A.* 2011;108(18):7517–7522.
 46. Calamito M, Juntilla MM, Thomas M, et al. Akt1 and Akt2 promote peripheral B-cell maturation and survival. *Blood.* 2010;115(20):4043–4050.
 47. Werner M, Hobeika E, Jumaa H. Role of PI3K in the generation and survival of B cells. *Immunol Rev.* 2010;237(1):55–71.
 48. Szydłowski M, Jabłonska E, Juszczynski P. FOXO1 transcription factor: a critical effector of the PI3K-AKT axis in B-cell development. *Int Rev Immunol.* 2014;33(2):146–157.
 49. van de Laar L, van den Bosch A, Boonstra A, et al. PI3K-PKB hyperactivation augments human plasmacytoid dendritic cell development and function. *Blood.* 2012;120(25):4982–4991.
 50. van de Laar L, Buitenhuis M, Wensveen FM, et al. Human CD34-derived myeloid dendritic cell development requires intact phosphatidylinositol 3-kinase-protein kinase B-mammalian target of rapamycin signaling. *J Immunol.* 2010;184(12):6600–6611.
 51. Mattioli B, Giordani L, Quaranta MG, et al. Leptin exerts an anti-apoptotic effect on human dendritic cells via the PI3K-Akt signaling pathway. *FEBS Lett.* 2009;583(7):1102–1106.
 52. Park D, Lapteva N, Seethamagari M, et al. An essential role for Akt1 in dendritic cell function and tumor immunotherapy. *Nat Biotechnol.* 2006;24(12):1581–1590.
 53. Arranz A, Doxaki C, Vergadi E, et al. Akt1 and Akt2 protein kinases differentially contribute to macrophage polarization. *Proc Natl Acad Sci U S A.* 2012;109(24):9517–9522.
 54. Busca A, Saxena M, Iqbal S, et al. PI3K/Akt regulates survival during differentiation of human macrophages by maintaining NF-kappaB-dependent expression of antiapoptotic Bcl-xL. *J Leukoc Biol.* 2014;96(6):1011–1022.
 55. Chen J, Tang H, Hay N, et al. Akt isoforms differentially regulate neutrophil functions. *Blood.* 2010;115(21):4237–4246.
 56. Shimobayashi M, Hall MN. Making new contacts: the mTOR network in metabolism and signalling crosstalk. *Nat Rev Mol Cell Biol.* 2014;15(3):155–162.
 57. Frauwirth KA, Riley JL, Harris MH, et al. The CD28 signaling pathway regulates glucose metabolism. *Immunity.* 2002;16(6):769–777.
 58. Rathmell JC, Vander Heiden MG, Harris MH, et al. In the absence of extrinsic signals, nutrient utilization by lymphocytes is insufficient to maintain either cell size or viability. *Mol Cell.* 2000;6(3):683–692.
 59. Barthel A, Okino ST, Liao J, et al. Regulation of GLUT1 gene transcription by the serine/threonine kinase Akt1. *J Biol Chem.* 1999;274(29):20281–20286.
 60. Rathmell JC, Fox CJ, Plas DR, et al. Akt-directed glucose metabolism can prevent Bax conformation change and promote growth factor-independent survival. *Mol Cell Biol.* 2003;23(20):7315–7328.
 61. Wieman HL, Wofford JA, Rathmell JC. Cytokine stimulation promotes glucose uptake via phosphatidylinositol-3 kinase/Akt regulation of Glut1 activity and trafficking. *Mol Biol Cell.* 2007;18(4):1437–1446.
 62. Jacobs SR, Herman CE, Maciver NJ, et al. Glucose uptake is limiting in T cell activation and requires CD28-mediated Akt-dependent and independent pathways. *J Immunol.* 2008;180(7):4476–4486.
 63. Gubser PM, Bantug GR, Razik L, et al. Rapid effector function of memory CD8+ T cells requires an immediate-early glycolytic switch. *Nat Immunol.* 2013;14(10):1064–1072.
 64. Macintyre AN, Finlay D, Preston G, et al. Protein kinase B controls transcriptional programs that direct cytotoxic T cell fate but is dispensable for T cell metabolism. *Immunity.* 2011;34(2):224–236.
 65. Sullivan JA, Kim EH, Plisch EH, et al. FOXO3 regulates CD8 T cell memory by T cell-intrinsic mechanisms. *PLoS Pathog.* 2012;8(2):e1002533.
 66. Kim EH, Suresh M. Role of PI3K/Akt signaling in memory CD8 T cell differentiation. *Front Immunol.* 2013;4:20.
 67. Sauer S, Bruno L, Hertweck A, et al. T cell receptor signaling controls Foxp3 expression via PI3K, Akt, and mTOR. *Proc Natl Acad Sci U S A.* 2008;105(22):7797–7802.
 68. Haxhinasto S, Mathis D, Benoist C. The AKT-mTOR axis regulates de novo differentiation of CD4+Foxp3+ cells. *J Exp Med.* 2008;205(3):565–574.
 69. Crellin NK, Garcia RV, Levings MK. Altered activation of AKT is required for the suppressive function of human CD4+CD25+ T regulatory cells. *Blood.* 2007;109(5):2014–2022.
 70. Coffey PJ, Burgering BM. Forkhead-box transcription factors and their role in the immune system. *Nat Rev Immunol.* 2004;4(11):889–899.
 71. Kerdiles YM, Stone EL, Beisner DR, et al. Foxo transcription factors control regulatory T cell development and function. *Immunity.* 2010;33(6):890–904.
 72. Rao RR, Li Q, Gubbels Bupp MR, et al. Transcription factor Foxo1 represses T-bet-mediated effector functions and promotes memory CD8(+) T cell differentiation. *Immunity.* 2012;36(3):374–387.
 73. Harada Y, Harada Y, Elly C, et al. Transcription factors Foxo3a and Foxo1 couple the E3 ligase Cbl-b to the induction of Foxp3 expression in induced regulatory T cells. *J Exp Med.* 2010;207(7):1381–1391.
 74. Ouyang W, Beckett O, Ma Q, et al. Foxo proteins cooperatively control the differentiation of Foxp3+ regulatory T cells. *Nat Immunol.* 2010;11(7):618–627.
 75. Merkenschlager M, von Boehmer H. PI3 kinase signalling blocks Foxp3 expression by sequestering Foxo factors. *J Exp Med.* 2010;207(7):1347–1350.
 76. Ouyang W, Liao W, Luo CT, et al. Novel Foxo1-dependent transcriptional programs control T(reg) cell function. *Nature.* 2012;491(7425):554–559.
 77. Nakano K, Higashi T, Hashimoto K, et al. Antagonizing dopamine D1-like receptor inhibits Th17 cell differentiation: preventive and therapeutic effects on experimental autoimmune encephalomyelitis. *Biochem Biophys Res Commun.* 2008;373(2):286–291.
 78. Zhou L, Lopes JE, Chong MM, et al. TGF-beta-induced Foxp3 inhibits T(H)17 cell differentiation by antagonizing RORgamma function. *Nature.* 2008;453(7192):236–240.
 79. Ichijima K, Yoshida H, Wakabayashi Y, et al. Foxp3 inhibits RORgamma-mediated IL-17A mRNA transcription through direct interaction with RORgamma. *J Biol Chem.* 2008;283(25):17003–17008.
 80. Kurebayashi Y, Nagai S, Ikejiri A, et al. PI3K-Akt-mTORC1-S6K1/2 axis controls Th17 differentiation by regulating Gfi1 expression and nuclear translocation of RORgamma. *Cell Rep.* 2012;1(4):360–373.
 81. Wohlfert EA, Grainger JR, Bouladoux N, et al. GATA3 controls Foxp3(+) regulatory T cell fate during inflammation in mice. *J Clin Invest.* 2011;121(11):4503–4515.
 82. Hwang ES, Szabo SJ, Schwartzberg PL, et al. T helper cell fate specified by kinase-mediated interaction of T-bet with GATA-3. *Science.* 2005;307(5708):430–433.
 83. Kadri Z, Maouche-Chretien L, Rooke HM, et al. Phosphatidylinositol 3-kinase/Akt induced by erythropoietin renders the erythroid differentiation factor GATA-1 competent for TIMP-1 gene transactivation. *Mol Cell Biol.* 2005;25(17):7412–7422.

84. Menghini R, Marchetti V, Cardellini M, et al. Phosphorylation of GATA2 by Akt increases adipose tissue differentiation and reduces adipose tissue-related inflammation: a novel pathway linking obesity to atherosclerosis. *Circulation*. 2005;111(15):1946–1953.
85. Ho IC, Tai TS, Pai SY. GATA3 and the T-cell lineage: essential functions before and after T-helper-2-cell differentiation. *Nat Rev Immunol*. 2009;9(2):125–135.
86. Tlsty TD, Coussens LM. Tumor stroma and regulation of cancer development. *Annu Rev Pathol*. 2006;1:119–150.
87. Ran C, Liu H, Hitoshi Y, et al. Proliferation-independent control of tumor glycolysis by PDGFR-mediated AKT activation. *Cancer Res*. 2013;73(6):1831–1843.
88. Elstrom RL, Bauer DE, Buzzai M, et al. Akt stimulates aerobic glycolysis in cancer cells. *Cancer Res*. 2004;64(11):3892–3899.
89. Coloff JL, Macintyre AN, Nichols AG, et al. Akt-dependent glucose metabolism promotes Mcl-1 synthesis to maintain cell survival and resistance to Bcl-2 inhibition. *Cancer Res*. 2011;71(15):5204–5213.
90. Sun Q, Chen X, Ma J, et al. Mammalian target of rapamycin up-regulation of pyruvate kinase isoenzyme type M2 is critical for aerobic glycolysis and tumor growth. *Proc Natl Acad Sci U S A*. 2011;108(10):4129–4134.
91. Ward PS, Thompson CB. Metabolic reprogramming: a cancer hallmark even warburg did not anticipate. *Cancer Cell*. 2012;21(3):297–308.
92. Schrader J, Gordon-Walker TT, Aucott RL, et al. Matrix stiffness modulates proliferation, chemotherapeutic response, and dormancy in hepatocellular carcinoma cells. *Hepatology*. 2011;53(4):1192–1205.
93. Ohlund D, Elyada E, Tuveson D. Fibroblast heterogeneity in the cancer wound. *J Exp Med*. 2014;211(8):1503–1523.
94. Karagiannis GS, Poutahidis T, Erdman SE, et al. Cancer-associated fibroblasts drive the progression of metastasis through both paracrine and mechanical pressure on cancer tissue. *Mol Cancer Res*. 2012;10(11):1403–1418.
95. Hanahan D, Coussens LM. Accessories to the crime: functions of cells recruited to the tumor microenvironment. *Cancer Cell*. 2012;21(3):309–322.
96. Condeelis J, Singer RH, Segall JE. The great escape: when cancer cells hijack the genes for chemotaxis and motility. *Annu Rev Cell Dev Biol*. 2005;21:695–718.
97. McAllister SS, Weinberg RA. The tumour-induced systemic environment as a critical regulator of cancer progression and metastasis. *Nat Cell Biol*. 2014;16(8):717–727.
98. Sotsios Y, Ward SG. Phosphoinositide 3-kinase: a key biochemical signal for cell migration in response to chemokines. *Immunol Rev*. 2000;177:217–235.
99. Oeckinghaus A, Hayden MS, Ghosh S. Crosstalk in NF-kappaB signaling pathways. *Nat Immunol*. 2011;12(8):695–708.
100. Kane LP, Shapiro VS, Stokoe D, et al. Induction of NF-kappaB by the Akt/PKB kinase. *Curr Biol*. 1999;9(11):601–604.
101. Bai D, Ueno L, Vogt PK. Akt-mediated regulation of NFkappaB and the essentialness of NFkappaB for the oncogenicity of PI3K and Akt. *Int J Cancer*. 2009;125(12):2863–2870.
102. Dan HC, Cooper MJ, Cogswell PC, et al. Akt-dependent regulation of NF-kappaB is controlled by mTOR and Raptor in association with IKK. *Genes Dev*. 2008;22(11):1490–1500.
103. Hirota K, Yoshitomi H, Hashimoto M, et al. Preferential recruitment of CCR6-expressing Th17 cells to inflamed joints via CCL20 in rheumatoid arthritis and its animal model. *J Exp Med*. 2007;204(12):2803–2812.
104. Yamazaki T, Yang XO, Chung Y, et al. CCR6 regulates the migration of inflammatory and regulatory T cells. *J Immunol*. 2008;181(12):8391–8401.
105. Ito M, Teshima K, Ikeda S, et al. MicroRNA-150 inhibits tumor invasion and metastasis by targeting the chemokine receptor CCR6, in advanced cutaneous T-cell lymphoma. *Blood*. 2014;123(10):1499–1511.
106. Battaglia F, Delfino S, Merello E, et al. Hypoxia transcriptionally induces macrophage-inflammatory protein-3alpha/CCL-20 in primary human mononuclear phagocytes through nuclear factor (NF)-kappaB. *J Leukoc Biol*. 2008;83(3):648–662.
107. Li X, Syrovets T, Simmet T. The serine protease plasmin triggers expression of the CC-chemokine ligand 20 in dendritic cells via Akt/NF-kappaB-dependent pathways. *J Biomed Biotechnol*. 2012;2012:186710.
108. Harant H, Eldershaw SA, Lindley IJ. Human macrophage inflammatory protein-3alpha/CCL20/LARC/Exodus/SCYA20 is transcriptionally upregulated by tumor necrosis factor-alpha via a non-standard NF-kappaB site. *FEBS Lett*. 2001;509(3):439–445.
109. Pietila TE, Veckman V, Lehtonen A, et al. Multiple NF-kappaB and IFN regulatory factor family transcription factors regulate CCL19 gene expression in human monocyte-derived dendritic cells. *J Immunol*. 2007;178(1):253–261.
110. Wickremasinghe MI, Thomas LH, O’Kane CM, et al. Transcriptional mechanisms regulating alveolar epithelial cell-specific CCL5 secretion in pulmonary tuberculosis. *J Biol Chem*. 2004;279(26):27199–27210.
111. Mizukami Y, Kono K, Kawaguchi Y, et al. CCL17 and CCL22 chemokines within tumor microenvironment are related to accumulation of Foxp3+ regulatory T cells in gastric cancer. *Int J Cancer*. 2008;122(10):2286–2293.
112. Sekiya T, Miyamasu M, Imanishi M, et al. Inducible expression of a Th2-type CC chemokine thymus- and activation-regulated chemokine by human bronchial epithelial cells. *J Immunol*. 2000;165(4):2205–2213.
113. Wu Y, Deng J, Rychahou PG, et al. Stabilization of snail by NF-kappaB is required for inflammation-induced cell migration and invasion. *Cancer Cell*. 2009;15(5):416–428.
114. Maier HJ, Schmidt-Strassburger U, Huber MA, et al. NF-kappaB promotes epithelial-mesenchymal transition, migration and invasion of pancreatic carcinoma cells. *Cancer Lett*. 2010;295(2):214–228.
115. Zhou C, Liu J, Tang Y, et al. Inflammation linking EMT and cancer stem cells. *Oral Oncol*. 2012;48(11):1068–1075.
116. Kudo-Saito C, Shirako H, Takeuchi T, et al. Cancer metastasis is accelerated through immunosuppression during Snail-induced EMT of cancer cells. *Cancer Cell*. 2009;15(3):195–206.
117. Zhou BP, Deng J, Xia W, et al. Dual regulation of Snail by GSK-3beta-mediated phosphorylation in control of epithelial-mesenchymal transition. *Nat Cell Biol*. 2004;6(10):931–940.
118. Conley-LaComb MK, Saliganan A, Kandagatla P, et al. PTEN loss mediated Akt activation promotes prostate tumor growth and metastasis via CXCL12/CXCR4 signaling. *Mol Cancer*. 2013;12(1):85.
119. Hopken UE, Foss HD, Meyer D, et al. Up-regulation of the chemokine receptor CCR7 in classical but not in lymphocyte-predominant Hodgkin disease correlates with distinct dissemination of neoplastic cells in lymphoid organs. *Blood*. 2002;99(4):1109–1116.
120. Karnoub AE, Dash AB, Vo AP, et al. Mesenchymal stem cells within tumor stroma promote breast cancer metastasis. *Nature*. 2007;449(7162):557–563.
121. Elinav E, Nowarski R, Thaiss CA, et al. Inflammation-induced cancer: crosstalk between tumours, immune cells and microorganisms. *Nat Rev Cancer*. 2013;13(11):759–771.
122. Fridman WH, Pages F, Sautes-Fridman C, et al. The immune contexture in human tumours: impact on clinical outcome. *Nat Rev Cancer*. 2012;12(4):298–306.
123. Ruffell B, DeNardo DG, Affara NI, et al. Lymphocytes in cancer development: polarization towards pro-tumor immunity. *Cytokine Growth Factor Rev*. 2010;21(1):3–10.
124. Pollard JW. Tumour-educated macrophages promote tumour progression and metastasis. *Nat Rev Cancer*. 2004;4(1):71–78.
125. Qian BZ, Pollard JW. Macrophage diversity enhances tumor progression and metastasis. *Cell*. 2010;141(1):39–51.
126. Gregory AD, Houghton AM. Tumor-associated neutrophils: new targets for cancer therapy. *Cancer Res*. 2011;71(7):2411–2416.
127. Drake CG, Jaffee E, Pardoll DM. Mechanisms of immune evasion by tumors. *Adv Immunol*. 2006;90:51–81.
128. Zheng Y, Zha Y, Gajewski TF. Molecular regulation of T-cell anergy. *EMBO Rep*. 2008;9(1):50–55.
129. Nagaraj S, Gabrilovich DI. Tumor escape mechanism governed by myeloid-derived suppressor cells. *Cancer Res*. 2008;68(8):2561–2563.
130. Vesely MD, Kershaw MH, Schreiber RD, et al. Natural innate and adaptive immunity to cancer. *Annu Rev Immunol*. 2011;29:235–271.
131. de Visser KE, Eichten A, Coussens LM. Paradoxical roles of the immune system during cancer development. *Nat Rev Cancer*. 2006;6(1):24–37.
132. Schreiber RD, Old LJ, Smyth MJ. Cancer immunoeediting: integrating immunity’s roles in cancer suppression and promotion. *Science*. 2011;331(6024):1565–1570.
133. Keir ME, Butte MJ, Freeman GJ, et al. PD-1 and its ligands in tolerance and immunity. *Annu Rev Immunol*. 2008;26:677–704.
134. Greenwald RJ, Freeman GJ, Sharpe AH. The B7 family revisited. *Annu Rev Immunol*. 2005;23:515–548.
135. Chen DS, Irving BA, Hodi FS. Molecular pathways: next-generation immunotherapy--inhibiting programmed death-ligand 1 and programmed death-1. *Clin Cancer Res*. 2012;18(24):6580–6587.
136. Parsa AT, Waldron JS, Panner A, et al. Loss of tumor suppressor PTEN function increases B7-H1 expression and immunoresistance in glioma. *Nat Med*. 2007;13(1):84–88.
137. Kaur S, Uddin S, Platanias LC. The PI3’ kinase pathway in interferon signaling. *J Interferon Cytokine Res*. 2005;25(12):780–787.
138. Song M, Chen D, Lu B, et al. PTEN loss increases PD-L1 protein expression and affects the correlation between PD-L1 expression and clinical parameters in colorectal cancer. *PLoS One*. 2013;8(6):e65821.
139. Mittendorf EA, Phillips AV, Meric-Bernstam F, et al. PD-L1 expression in triple-negative breast cancer. *Cancer Immunol Res*. 2014;2(4):361–370.
140. Crane CA, Panner A, Murray JC, et al. PI(3) kinase is associated with a mechanism of immunoresistance in breast and prostate cancer. *Oncogene*. 2009;28(2):306–312.
141. Atefi M, Avramis E, Lassen A, et al. Effects of MAPK and PI3K pathways on PD-L1 expression in melanoma. *Clin Cancer Res*. 2014;20(13):3446–3457.
142. Zhang Y, Zhang J, Xu K, et al. PTEN/PI3K/mTOR/B7-H1 signaling pathway regulates cell progression and immuno-resistance in pancreatic cancer. *Hepatogastroenterology*. 2013;60(127):1766–1772.
143. Crompton JG, Sukumar M, Roychoudhuri R, et al. Akt inhibition enhances expansion of potent tumor-specific lymphocytes with memory cell characteristics. *Cancer Res*. 2015;75(2):296–305.
144. van der Waart AB, van de Weem NM, Maas F, et al. Inhibition of Akt signaling promotes the generation of superior tumor-reactive T cells for adoptive immunotherapy. *Blood*. 2014;124(23):3490–3500.
145. Abu-Eid R, Samara RN, Ozburn L, et al. Selective Inhibition of Regulatory T Cells by Targeting the PI3K-Akt Pathway. *Cancer Immunol Res*. 2014;2(11):1080–1089.
146. Ansell SM, Lesokhin AM, Borrello I, et al. PD-1 Blockade with Nivolumab in Relapsed or Refractory Hodgkin’s Lymphoma. *N Engl J Med*. 2014; In press.
147. Herbst RS, Soria JC, Kowanetz M, et al. Predictive correlates of response to the anti-PD-L1 antibody MPDL3280A in cancer patients. *Nature*. 2014;515(7528):563–567.

148. Yang P, Li QJ, Feng Y, et al. TGF-beta-miR-34a-CCL22 signaling-induced Treg cell recruitment promotes venous metastases of HBV-positive hepatocellular carcinoma. *Cancer Cell*. 2012;22(3):291–303.
149. Qian BZ, Li J, Zhang H, et al. CCL2 recruits inflammatory monocytes to facilitate breast-tumour metastasis. *Nature*. 2011;475(7355):222–225.
150. Noy R, Pollard JW. Tumor-associated macrophages: from mechanisms to therapy. *Immunity*. 2014;41(1):49–61.
151. Stegeman H, Span PN, Kaanders JH, et al. Improving chemoradiation efficacy by PI3-K/AKT inhibition. *Cancer Treat Rev*. 2014;40(10):1182–1191.
152. Hafsi S, Pezzino FM, Candido S, et al. Gene alterations in the PI3K/PTEN/AKT pathway as a mechanism of drug-resistance (review). *Int J Oncol*. 2012;40(3):639–644.
153. Noh KH, Kang TH, Kim JH, et al. Activation of Akt as a mechanism for tumor immune evasion. *Mol Ther*. 2009;17(3):439–447.
154. Kim EH, Sullivan JA, Plisch EH, et al. Signal integration by Akt regulates CD8 T cell effector and memory differentiation. *J Immunol*. 2012;188(9):4305–4514.
155. Hemon P, Jean-Louis F, Ramgolam K, et al. MHC class II engagement by its ligand LAG-3 (CD223) contributes to melanoma resistance to apoptosis. *J Immunol*. 2011;186(9):5173–5183.
156. Benitez AC, Dai Z, Mann HH, et al. Expression, signaling proficiency, and stimulatory function of the NKG2D lymphocyte receptor in human cancer cells. *Proc Natl Acad Sci U S A*. 2011;108(10):4081–4086.
157. Efimova OV, Kelley TW. Induction of granzyme B expression in T-cell receptor/CD28-stimulated human regulatory T cells is suppressed by inhibitors of the PI3K-mTOR pathway. *BMC Immunol*. 2009;10:59.
158. Patton DT, Garden OA, Pearce WP, et al. Cutting edge: the phosphoinositide 3-kinase p110 delta is critical for the function of CD4+CD25+Foxp3+ regulatory T cells. *J Immunol*. 2006;177(10):6598–6602.
159. Chapman PB, Hauschild A, Robert C, et al. Improved survival with vemurafenib in melanoma with BRAF V600E mutation. *N Engl J Med*. 2011;364(26):2507–2516.
160. Schilling B, Sucker A, Griewank K, et al. Vemurafenib reverses immunosuppression by myeloid derived suppressor cells. *Int J Cancer*. 2013;133(7):1653–1663.
161. Knight DA, Ngiow SF, Li M, et al. Host immunity contributes to the anti-melanoma activity of BRAF inhibitors. *J Clin Invest*. 2013;123(3):1371–1378.
162. Wilmott JS, Long GV, Howle JR, et al. Selective BRAF inhibitors induce marked T-cell infiltration into human metastatic melanoma. *Clin Cancer Res*. 2012;18(5):1386–1394.
163. Hu W, Jin L, Jiang CC, et al. AEBP1 upregulation confers acquired resistance to BRAF (V600E) inhibition in melanoma. *Cell Death Dis*. 2013;4:e914.
164. Koya RC, Mok S, Otte N, et al. BRAF inhibitor vemurafenib improves the anti-tumor activity of adoptive cell immunotherapy. *Cancer Res*. 2012;72(16):3928–3937.
165. Wang S, Basson MD. Akt directly regulates focal adhesion kinase through association and serine phosphorylation: implication for pressure-induced colon cancer metastasis. *Am J Physiol Cell Physiol*. 2011;300(3):C657–C670.
166. Santoro MM, Gaudino G, Marchisio PC. The MSP receptor regulates alpha-6beta4 and alpha3beta1 integrins via 14-3-3 proteins in keratinocyte migration. *Dev Cell*. 2003;5(2):257–271.
167. Santoro MM, Gaudino G, Villa-Moruzzi E. Protein phosphatase 1 binds to phospho-Ser-1394 of the macrophage-stimulating protein receptor. *Biochem J*. 2003;376(Pt 3):587–594.
168. Chan CB, Liu X, Tang X, et al. Akt phosphorylation of zyxin mediates its interaction with acinus-S and prevents acinus-triggered chromatin condensation. *Cell Death Differ*. 2007;14(9):1688–1699.
169. Deterding LJ, Williams JG, Humble MM, et al. CD34 Antigen: Determination of Specific Sites of Phosphorylation In Vitro and In Vivo. *Int J Mass Spectrom*. 2011;301(1–3):12–21.
170. Kim H, Han JR, Park J, et al. Delta-catenin-induced dendritic morphogenesis. An essential role of p190RhoGEF interaction through Akt1-mediated phosphorylation. *J Biol Chem*. 2008;283(2):977–987.
171. van der Waart AB, van de Weem NM, Maas F, et al. Inhibition of Akt-signaling promotes the generation of superior tumor-reactive T cells for adoptive immunotherapy. *Blood*. 2014;124(23):3490–3500.