

A ToxR-based two-hybrid system for the detection of periplasmic and cytoplasmic protein–protein interactions in *Escherichia coli*: minimal requirements for specific DNA binding and transcriptional activation

Frank Hennecke^{1,2}, Arne Müller^{1,3}, Roland Meister^{1,4},
Astrid Strelow^{1,5} and Susanne Behrens^{1,6}

¹Abteilung Molekulare Genetik und Präparative Molekularbiologie, Institut für Mikrobiologie und Genetik, Georg-August-Universität Göttingen, Grisebachstrasse 8, D-37077 Göttingen, Germany

²Present address: Cytos Biotechnology AG, Wagsisstrasse 25, CH-8952 Zürich-Schlieren, Switzerland

³Present address: Bioinformatics, Sanofi Aventis SA, Centre de Recherche de Paris, 13 quai Jules Guesdes, 94400 Vitry-sur-Seine, France

⁴Present address: Medizinische Hochschule Hannover, Tissue Engineering Network, Podbielski Strasse 380, 30659 Hannover, Germany

⁵Present address: diaDexus Inc., 343 Oyster Point Boulevard, South San Francisco, CA 94080, USA

⁶To whom correspondence should be addressed.
E-mail: sbehren1@gwdg.de

The *Vibrio cholerae* transcriptional regulator ToxR is anchored in the cytoplasmic membrane by a single transmembrane segment, its C-terminal domain facing the periplasm. Most of its N-terminal cytoplasmic domain shares sequence similarity with the winged helix–turn–helix (wHTH) motif of OmpR-like transcriptional regulators. In the heterologous host *Escherichia coli* ToxR activates transcription at the *V.cholerae* *ctx* promoter in a dimerization-dependent manner, which has led to its employment as a genetic indicator for protein–protein interactions. However, although offering a broader potential application range than other prokaryotic two-hybrid systems described to date, ToxR has so far only been used to study interactions between heterologous transmembrane segments or to monitor homodimerization of C-terminal fusion partners in the periplasm and the cytoplasm of *E.coli*. Here we show that the ToxR-system also allows the detection of heterodimerization in both cellular compartments of *E.coli*. In addition, to better understand ToxR's mode of action at *ctx* in *E.coli*, we have investigated the minimal requirements for its function as a transcriptional activator. We show that the wHTH motif of ToxR's N-terminal domain constitutes the minimal structural element required to activate transcription at *ctx* in *E.coli* when fused to a dimerizing protein module.

Keywords: DNA binding/leucine zipper/protein–protein interaction/ToxR/two-hybrid system

Introduction

In the human pathogen *Vibrio cholerae*, the signal transduction protein ToxR functions as a global transcriptional regulator in a complex regulatory cascade that controls the coordinate expression of virulence genes, including the *ctxAB* cholera

toxin genes. ToxR is the prototype of a small unique family of regulatory proteins that are localized to the cytoplasmic membrane and yet regulate gene expression by binding DNA and activating transcription. The bitopic protein is anchored in the membrane by a single membrane-spanning segment, its N- and C-terminal domains facing the cytoplasm and the periplasm, respectively. Much of the cytoplasmic domain shares sequence similarity with the DNA binding/transcription activation winged helix–turn–helix (wHTH) motif of OmpR-like transcriptional activators (Martínez-Hackert and Stock, 1997; Krukoniš *et al.*, 2000).

The transcriptional activation of the *ctxAB* genes in *V.cholerae* only indirectly involves ToxR (DiRita *et al.*, 1991; Higgins *et al.*, 1992). In the heterologous host *Escherichia coli*, in contrast, ToxR is capable of directly activating transcription at *ctx* (Miller and Mekalanos, 1984) (Figure 1). The *ctx* promoter is characterized by a heptameric DNA

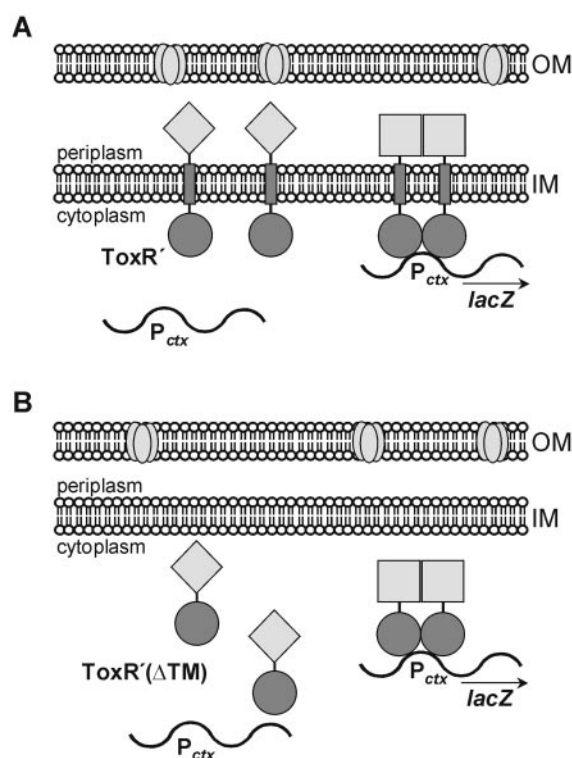

Fig. 1. The ToxR-based two-hybrid system for the detection of protein–protein interactions in the *E.coli* periplasm (A) and cytoplasm (B). In fusion with non-interacting heterologous protein modules (diamonds), the membrane-anchored (ToxR^l) and the soluble [ToxR^l(Δ TM)] N-terminal ToxR domains (circles) remain monomeric and transcription of the *lacZ* gene under *ctx* promoter (P_{ctx}) control is not activated. The interaction of dimerizing heterologous fusion partners (squares) leads to the dimerization of the N-terminal ToxR domains and, as a result of dimerization, to activation of *lacZ* transcription at *ctx*.

element (TTTTGAT) located 56 bp upstream of the transcription start site and directly repeated 3–8 times, depending on the *V.cholerae* strain. At least three copies of the heptad and additional sequences near the –35 promoter region are required for binding and transcriptional activation of *ctx* by ToxR (Miller et al., 1987; Pfau and Taylor, 1996). In *E.coli*, ToxR's function as a transcriptional activator of *ctx* furthermore requires the dimerization of its N-terminal DNA-binding domain. This was first deduced from the finding that the homodimeric enzyme alkaline phosphatase could functionally substitute for the periplasmic ToxR domain (Miller et al., 1987; DiRita and Mekalanos, 1991). Later studies supported the dimerization model by showing that the DNA-binding domain of phage λ cI repressor dimerizes and represses transcription from a lambda $O_R1P_R:lacZY$ reporter fusion in *E.coli* when N-terminally fused to ToxR (Dziejman and Mekalanos, 1994).

ToxR's modular organization and its dimerization-dependent function as transcriptional activator of *ctx* in *E.coli* allow for its use as a genetic indicator for protein–protein interactions. ToxR's periplasmic domain and its transmembrane segment can be replaced by heterologous protein modules or transmembrane segments, respectively, allowing the analysis of protein interactions and protein stability in the periplasm (Figure 1A) and also of interactions between transmembrane segments (Kolmar et al., 1994, 1995a,b; Langosch et al., 1996; Russ and Engelman, 1999). In addition, ToxR has been demonstrated to be of use for the identification of protein interactions in the cytoplasmic compartment of *E.coli* using variants of ToxR that lack the transmembrane segment (Kolmar et al., 1995a) (Figure 1B). In these studies, either a chromosomal *ctx::lacZ* (Figure 1) or a plasmid-encoded *ctx::chloramphenicol acetyl transferase* reporter fusion served to measure ToxR activity (Kolmar et al., 1994; Russ and Engelman, 1999).

Allowing the assessment of protein interactions in the inner membrane and in both cellular compartments of *E.coli*, ToxR provides a broader potential application range than existing prokaryotic two-hybrid systems. So far, however, ToxR's technical utility to detect protein–protein interactions in the cytoplasmic and periplasmic compartments has only been demonstrated using homodimerizing model proteins (Kolmar et al., 1995a). In this study, we show that the ToxR-system is also applicable to monitor asymmetric interactions between heterologous fusion partners in both cellular compartments of *E.coli*. Furthermore, to enhance ToxR's applicability as a prokaryotic two-hybrid system, a better understanding of its mode of action at the *ctx* promoter in *E.coli* is required. Therefore, we have investigated the minimal requirements for its function as a transcriptional activator of *ctx* in *E.coli*. We show that a short hinge region of ToxR, which lies between the wHTH domain and the transmembrane segment, is responsible for mediating ToxR–ToxR interactions *in vitro* but is not required either for specific DNA binding *in vitro* or for *ctx* activation in *E.coli*. Hence the conserved wHTH motif of ToxR's N-terminal DNA-binding domain defines the minimal structural element required for ToxR-mediated, dimerization-dependent transcriptional activation at *ctx* in *E.coli*.

Materials and methods

Growth media

Luria–Bertani (LB) and dYT media were prepared as described (Sambrook et al., 1989) and supplemented with 100 μ g/ml

ampicillin (Ap) and 25 μ g/ml chloramphenicol (Cm) if required.

Bacterial strains and plasmids

All strains and plasmids used in this study are listed in Table I. A detailed description of their construction is given in the Supplementary data available at PEDS Online under 'Plasmid constructions'. To study ToxR-mediated transcriptional activation *in vivo*, vectors of the pHK series were used in which the chimeric *toxR* genes are under transcriptional control of the *V.cholerae toxR* promoter (Kolmar et al., 1994). To study asymmetric protein–protein interactions, pHK-based vectors carrying two chimeric *toxR'* fusion genes including their up- and downstream transcriptional regulatory sequences were used, which allow the co-production of both ToxR' proteins at balanced molar levels within each cell.

To produce chimeric ToxR proteins and MalE fusion proteins for purification, plasmids of the pASK- (*toxR'* fusion genes under *tet* promoter control; Skerra, 1994), the pBSK- (*toxR'* fusion genes under *lac* promoter control; Stratagene) and the pMal-c series (*malE* genes under *tac* promoter control; New England Biolabs) were used.

In vivo assay for ToxR-mediated transcriptional activation and western blot analysis

ToxR-mediated transcriptional activation was assayed by monitoring β -galactosidase activity from the chromosomal *ctx::lacZ* reporter fusion in *E.coli* FHK12 (Kolmar et al., 1995a). FHK12 was freshly transformed with equal amounts of the pHKToxR' plasmids and plated on LB/Cm plates. Single colonies were taken and transferred into 5 ml of LB/Cm supplemented with 0.3 mM isopropyl- β -thiogalactoside (IPTG) and grown for 10–12 h at 30°C. β -Galactosidase activity was then determined from 15 μ l of culture as described by Kolmar et al. (1995a). In addition, samples of these cultures containing 10^8 cells were analyzed by western blotting using MalE-specific antibodies (New England Biolabs; 1:10 000 dilution). Anti-rabbit alkaline phosphatase (Sigma-Aldrich; 1:10 000 dilution) was used as the secondary antibody. The blots were developed by incubation in reaction buffer (100 mM Tris–HCl pH 8.8, 100 mM NaCl, 5 mM MgCl₂, 37.5 μ g/ml NBT, 150 μ g/ml BCIP).

Protein production and purification

MalE, MalEGCN, ToxR'(Δ TM)MalE and ToxR'(Δ TM)MalEGCN were produced from the respective pMal-c and pBSIISK(–) plasmids in *E.coli* PD28 (Table I). Cultures were grown in LB/Ap at 30°C and production of the recombinant proteins was induced with 0.5 mM IPTG at an OD₆₀₀ of 0.3–0.5 followed by further incubation for 3–5 h. Cells were pelleted by centrifugation (4000 g, 40 min, 4°C), resuspended in amylose A buffer (50 mM Tris–HCl, pH 7.5, 2.5 mM β -mercaptoethanol) with 1 mM PMSF and lysed by French press treatment and sonication. The cell extract was cleared by centrifugation (15 000 g, 40 min, 4°C) and mixed with amylose resin (New England Biolabs) pre-equilibrated with amylose A buffer. After 30 min of incubation on ice the mix was centrifuged (4000 g, 10 min, 4°C) and the supernatant removed. The amylose resin was washed three times in amylose-wash buffer (amylose A buffer with 0.5 M NaCl) and once with amylose A buffer. The MalE fusion proteins were then eluted by incubation in amylose B buffer (amylose A buffer with 10 mM

Table I. Bacterial strains and plasmids

| Strain/plasmid | Description/relevant genotype | Reference/source |
|---|--|------------------------------|
| <i>Strain</i> | | |
| FHK12 | F' <i>lacF^q lacZΔM15 proA⁺B⁺ ara Δ(lac-proAB) rpsL φ80dlacΔM15 attB::(bla, ctx::lacZ)</i> , Ap ^R | Kolmar <i>et al.</i> (1995a) |
| HS3018 | MC4100 <i>malT^c-1 ΔmalE444</i> | Shuman (1982) |
| PD28 | F' <i>thiA relA araD139 ΔlacU169 rpsL malT^c-1 ΔmalE444 Δ(srl-recA)306::Tn10</i> | Duplay <i>et al.</i> (1987) |
| <i>Plasmids</i> | | |
| pASK75 | Expression vector, P _{tet} , ColE1 ori, Ap ^R | Skerra (1994) |
| pASKToxR'(ΔTM)-Int | <i>toxR</i> codons 1–182+199–210 (<i>toxR'</i> (ΔTM)) fused to the <i>intein-cbd^a</i> gene in pASK75, Ap ^R | This work |
| pASKToxR'(ΔTM)GCN-Int | <i>toxR'</i> (ΔTM)GCN- <i>intein-cbd</i> fusion gene in pASK75, Ap ^R | This work |
| pASKToxR'(ΔTM)(ΔX)-Int | <i>toxR'</i> (ΔTM)- <i>intein-cbd</i> fusion gene lacking <i>toxR</i> codons 198–210 in pASK75, Ap ^R | This work |
| pASKToxR'(ΔTM)(ΔX)GCN-Int | <i>toxR'</i> (ΔTM)GCN- <i>intein-cbd</i> fusion gene lacking <i>toxR</i> codons 198–210 in pASK75, Ap ^R | This work |
| pASKToxR'(Δ123–181)(ΔTM)(ΔX)GCN-Int | <i>toxR'</i> (ΔTM) (ΔX) GCN- <i>intein-cbd</i> fusion gene lacking <i>toxR</i> codons 123–181 in pASK75, Ap ^R | This work |
| pASKToxR'(Δ139–181)(ΔTM)(ΔX)-Int | <i>toxR'</i> (ΔTM) (ΔX)- <i>intein-cbd</i> fusion gene lacking <i>toxR</i> codons 139–181 in pASK75, Ap ^R | This work |
| pASKToxR'(Δ139–181)(ΔTM)(ΔX)GCN-Int | <i>toxR'</i> (ΔTM) (ΔX) GCN- <i>intein-cbd</i> fusion gene lacking <i>toxR</i> codons 139–181 in pASK75, Ap ^R | This work |
| pBSIISK(-) | Expression vector, P _{lac} , Ap ^R | Stratagene |
| pBSK(-)ctx-21 | <i>ctx</i> promoter fragment in pBSIISK(-), Ap ^R | This work |
| pBSK(-)HELE35Q | <i>helE35Q</i> -fragment in pBSIISK(-), Ap ^R | This work |
| pBSKToxR'(ΔTM)MalE | <i>toxR'</i> (ΔTM) <i>malE</i> fusion gene in pBSIISK(-), Ap ^R | This work |
| pBSKToxR'(ΔTM)MalEGCN | <i>toxR'</i> (ΔTM) <i>malEGCN</i> fusion gene in pBSIISK(-), Ap ^R | This work |
| pHK vector series | Expression vector for β-galactosidase assays; P/O _{toxR} , F1 ori, ColE1 ori, Cm ^R | Kolmar <i>et al.</i> (1994) |
| pHKToxR'MalE | <i>toxR'</i> <i>malE</i> fusion gene in pHK, Cm ^R | Kolmar <i>et al.</i> (1995a) |
| pHKToxR'MalEGCN ^b | <i>toxR'</i> <i>malEGCN</i> fusion gene in pHK, Cm ^R | Kolmar <i>et al.</i> (1995a) |
| pHKToxR'MalEFos | <i>toxR'</i> <i>malEFos</i> fusion gene in pHK, Cm ^R | This work |
| pHKToxR'MalEJun | <i>toxR'</i> <i>malEjun</i> fusion gene in pHK, Cm ^R | This work |
| pHKToxR'MalEJun ^{L14F/L21H} | <i>toxR'</i> <i>malEjunL14F/L21H</i> fusion gene in pHK, Cm ^R | This work |
| pHKToxR'MalEFos/ToxR'MalEJun | <i>toxR'</i> <i>malEFos</i> and <i>toxR'</i> <i>malEjun</i> fusion genes in pHK, Cm ^R | This work |
| pHKToxR'MalEFos/ToxR'MalEJun ^{L14F/L21H} | <i>toxR'</i> <i>malEFos</i> and <i>toxR'</i> <i>malEjunL14F/L21H</i> fusion genes in pHK, Cm ^R | This work |
| pHKToxR'(ΔTM) | <i>toxR</i> codons 1–182+199–210 (<i>toxR'</i> (ΔTM)) in pHK, Cm ^R | This work |
| pHKToxR'(ΔTM)(ΔX) ^c | <i>toxR'</i> (ΔTM) gene with stop codon in position 182 in pHK, Cm ^R | Kolmar <i>et al.</i> (1995a) |
| pHKToxR'(ΔTM)MalE | <i>toxR'</i> (ΔTM) <i>malE</i> fusion gene in pHK, Cm ^R | Kolmar <i>et al.</i> (1995a) |
| pHKToxR'(ΔTM)MalEGCN ^b | <i>toxR'</i> (ΔTM) <i>malEGCN</i> fusion gene in pHK, Cm ^R | Kolmar <i>et al.</i> (1995a) |
| pHKToxR'(ΔTM)MalEFos | <i>toxR'</i> (ΔTM) <i>malEFos</i> fusion gene in pHK, Cm ^R | This work |
| pHKToxR'(ΔTM)MalEJun | <i>toxR'</i> (ΔTM) <i>malEjun</i> fusion gene in pHK, Cm ^R | This work |
| pHKToxR'(ΔTM)MalEJun ^{L14F/L21H} | <i>toxR'</i> (ΔTM) <i>malEjunL14F/L21H</i> fusion gene in pHK, Cm ^R | This work |
| pHKToxR'(ΔTM)MalEFos/ToxR'(ΔTM)MalEJun | <i>toxR'</i> (ΔTM) <i>malEFos</i> and <i>toxR'</i> (ΔTM) <i>malEjun</i> fusion genes in pHK, Cm ^R | This work |
| pHKToxR'(ΔTM)MalEFos/ToxR'(ΔTM)MalEJun ^{L14F/L21H} | <i>toxR'</i> (ΔTM) <i>malEFos</i> and <i>toxR'</i> (ΔTM) <i>malEjunL14F/L21H</i> fusion genes in pHK, Cm ^R | This work |
| pHKToxR'(ΔTM)GCN ^b | <i>toxR'</i> (ΔTM)GCN fusion gene in pHK, Cm ^R | Kolmar <i>et al.</i> (1995a) |
| pHKToxR'(ΔTM)(ΔX)GCN | <i>toxR'</i> (ΔTM)(ΔX)GCN fusion gene in pHK, Cm ^R | This work |
| pHKToxR'(Δ123–181)(ΔTM)(ΔX)GCN | <i>toxR'</i> (Δ123–181)(ΔTM)(ΔX)GCN fusion gene in pHK, Cm ^R | This work |
| pHKToxR'(Δ139–181)(ΔTM)(ΔX)GCN | <i>toxR'</i> (Δ139–181)(ΔTM)(ΔX)GCN fusion gene in pHK, Cm ^R | This work |
| pMal-c | Expression vector, P _{tac} , ColE1 ori, Ap ^R | New England Biolabs |
| pMalcMalE | <i>malE</i> gene in pMal-c | This work |
| pMalcMalEGCN | <i>malEGCN</i> fusion gene in pMal-c | This work |

^acbd = chitin-binding domain.

^bGCN referred to as Zip in Kolmar *et al.* (1995a).

^cReferred to as pHKToxR'(ΔTM) in Kolmar *et al.* (1995a).

maltose) for 30 min on ice and subsequent centrifugation. The protein containing supernatant was dialyzed and concentrated. The typical protein yield from this protocol was ~8 mg of MalE or MalEGCN protein per 50 ml of cell culture and ~0.25 mg of the ToxR'(ΔTM) fusion proteins per liter of cell culture.

The ToxR'(ΔTM), ToxR'(ΔTM)GCN, ToxR'(ΔTM)(ΔX), ToxR'(ΔTM)(ΔX)GCN, ToxR'(Δ139–181)(ΔTM)(ΔX) and ToxR'(Δ139–181)(ΔTM)(ΔX)GCN proteins were produced and purified using the IMPACT expression system (New England Biolabs). The proteins were produced in fusion with the Intein-CBD (Intein-chitin-binding domain) protein from pASK-plasmids in *E. coli* HS3018 (Table I). Cultures

were grown in LB/Ap at 37°C to an OD₆₀₀ of 0.5 and the production of the recombinant proteins was induced with 0.2 μg/ml anhydrotetracycline. After growth for a further 2–3 h, cells were harvested by centrifugation (4000 g, 40 min, 4°C), resuspended in CB buffer (40 mM Tris-HCl, pH 8.5, 500 mM NaCl, 1 mM EDTA, 0.1% Triton X-100) supplemented with 75 units of Benzonase (Merck) and lysed by French press treatment and subsequent sonication. The cell extract was cleared by centrifugation (15 000 g, 40 min, 4°C) and applied to a 6–8 ml chitin beads column (New England Biolabs) pre-equilibrated with CB buffer. The column was washed with CB-wash buffer (CB buffer with 1 M NaCl), sealed and incubated for 30 min at room temperature to release ToxR-bound DNA,

which was then removed with 10 volumes of CB-wash buffer. The column was equilibrated with 10 volumes of DNase buffer (50 mM Tris-HCl, pH 8.0, 3 mM MgCl₂) and incubated in 1 volume of DNase-buffer with 75 units of Benzonase for 30 min at 37°C to digest residual DNA. After washing the column with 10 volumes of CB buffer, three volumes of cleavage buffer (CB buffer with 150 mM DTT) were applied and the sealed column was incubated at room temperature for 16–24 h. Finally, the proteins were eluted with 5 volumes of CB buffer, dialyzed and concentrated to 5–10 mg/ml. Typical protein yield from this protocol was 3–6 mg of ToxR'(ΔTM) fusion protein per liter of cell culture.

Protein preparations were confirmed to be free of contaminating DNA and of residual DNase activity. Protein concentrations were determined spectrophotometrically with absorption coefficients calculated according to Pace *et al.* (1995).

Gel filtration analysis

Apparent molecular protein weights were determined by gel filtration on an FPLC Superdex 200 HR 10/30 column (Pharmacia) at 4°C in gel filtration buffer (40 mM Tris-HCl pH 7.5, 500 mM NaCl, 1 mM EDTA) and a flow rate of 0.5 ml/min. The proteins were applied to the column in 50–100 µl samples at the concentrations indicated in Table II. Molecular weight standard proteins (Pharmacia) were used for column calibration.

Electrophoretic mobility shift assays

The *ctx-* (209 bp) and *hel-* (410 bp) DNA fragments were amplified from the pBSK(-)ctx-21 and pBSK(-)HELE35Q plasmids by standard PCR using the primer pairs Suctxup (5'-GGAATTCTAGAAAGTGAAACGGGGT-3')/SuctxΔsig (5'-GGAATTCTAGAAAGTGAAACGGGGT-3') and Hellup (5'-GTCGACCCCGGGAAAGTC-3')/Hello (5'-CGCGGTTCTAGATTATCACAGCCGGCAGCCTCTG-3'), respectively. The fragments were purified from agarose gels and subsequently cleaved with *EcoRI* and *XbaI*, respectively (restriction sites underlined), to generate 5'-overhangs. After inactivation of the enzymes by heat treatment, the DNA fragments were radioactively labeled in a standard fill-in reaction using Klenow DNA polymerase and α[³²P]dATP (Sambrook *et al.*, 1989).

For gel retardation analysis, 50 fmol of radiolabeled DNA was incubated in 50 µl of shift buffer (40 mM Tris-HCl, pH 7.5, 50 mM NaCl, 1 mM EDTA, 0.1 mM DTT, 5% glycerol, 50 µg/ml BSA) with 500 ng of salmon sperm DNA (in 56- and 37-fold excess with regard to *ctx-* and *hel-*DNA, respectively) and 0–80 pmol of protein for 30 min at room temperature. The samples were loaded directly on a 6% TBE polyacrylamide gel (200×250×1.5 mm) and run overnight with 0.5× TBE running buffer at room temperature and 4–8 mA. Radiolabeled DNA was visualized by exposure to X-ray film for 2–12 h at -70°C.

Analysis of protein-DNA interactions by surface plasmon resonance spectroscopy

The interaction of soluble ToxR proteins with *ctx-* and *hel-*DNA was analyzed by surface plasmon resonance spectroscopy (SPR) on a Biacore system 1000 (BIAcore AB) with biotinylated DNA fragments immobilized on a streptavidin chip (SA5, BIAcore AB). Interaction was detected by monitoring the mass concentration-dependent changes of the refractive index on the sensor surface, expressed as resonance units (RU).

Biotinylated Bio-*ctx-* (204 bp) and Bio-*hel-* (417 bp) DNA fragments were amplified from the pBSK(-)ctx21 and pBSK(-)HELE35Q plasmids by standard PCR using the primer pairs Bioctxup (5'-biotin-TCTAGAAGTGAAACGGGG-3')/Suctx-Δsig and Biohelup (5'-biotin-GTCGACCCCGGGAAAGTC-3')/Hello, respectively. The fragments were purified from agarose gels and immobilized on the SA5 sensor chip by injecting 25 µl of HBS buffer (10 mM HEPES pH 7.4, 150 mM NaCl, 3.4 mM EDTA, 0.005% Tween-20) containing 2.1 pmol/µl Bio-*ctx-* or Bio-*hel-* at a flow rate of 2 µl/min. Injection of Bio-*ctx-* resulted in 306 RU, injection of Bio-*hel-* in 253 RU, corresponding to final DNA densities on the chip surfaces of about 2.1 and 1.0 fmol/mm², respectively. The Bio-*ctx-* fragment was immobilized in 2-fold molar excess to compensate for the 2-fold length of the Bio-*hel-* fragment and thus to display comparable numbers of potential DNA binding sites on both chip surfaces.

For interaction studies, 20 pmol of protein in 10 µl of shift buffer (without BSA) were injected at a constant flow rate of 2 µl/min. The chip surfaces were regenerated by flushing with 10 ml of 1 M NaCl. All solutions used for SPR were filtered (0.22 µm) and degassed.

Table II. Oligomeric states of ToxR fusion proteins determined by gel filtration analysis

| Protein | Calculated M_r | Apparent M_r | Oligomeric state |
|-----------------------------|------------------|----------------------|------------------|
| MalE | 41 592 | 41 630 ^a | Monomer |
| MalEGCN | 45 925 | 76 770 ^a | Dimer |
| ToxR'(ΔTM)MalE | 63 025 | 77 560 ^b | Monomer |
| ToxR'(ΔTM)MalEGCN | 67 814 | 105 250 ^c | Dimer |
| ToxR'(ΔTM) | 21 800 | 45 783 ^b | Dimer |
| ToxR'(ΔTM)GCN | 26 300 | 125 170 ^b | Pentamer |
| ToxR'(ΔTM)(ΔX) | 20 664 | 40 523 ^b | Dimer |
| ToxR'(ΔTM)(ΔX)GCN | 24 999 | 112 876 ^b | Pentamer |
| ToxR'(Δ139–181)(ΔTM)(ΔX) | 16 384 | 19 196 ^b | Monomer |
| ToxR'(Δ139–181)(ΔTM)(ΔX)GCN | 20 700 | 52 481 ^b | Dimer/Trimer |

Analyzed protein: ^a50 µl of 0.8 mg protein/ml.

^b100 µl of 0.4 mg protein/ml.

^c50 µl of 0.2 mg protein/ml.

Results

Soluble and membrane-anchored heterodimerizing ToxR derivatives activate transcription at *ctx* in *E.coli*

Using the Bence Jones protein REI_v and the leucine zipper domain of the *Saccharomyces cerevisiae* transcriptional activator GCN4 (Hope and Struhl, 1987) as model proteins for homodimerization, it has previously been demonstrated that the ToxR-system allows the analysis of protein stability and the detection of symmetric protein interactions in both the cytoplasm and the periplasm of *E.coli* (Kolmar *et al.*, 1994, 1995a,b). To examine whether the ToxR system would also be applicable to detect asymmetric protein interactions in both cellular compartments, we chose here the leucine zippers of the transcriptional activators Jun and Fos (O'Shea *et al.*, 1989) as model proteins for heterodimerization. Since Jun has been reported also to form homodimers in absence of Fos, we used

the homodimerization-deficient Jun^{L14F/L21H} (Jun^{L14F/L21H}) protein (Smeal *et al.*, 1989) as a control. Furthermore, because it has been shown that ToxR derivatives in which the periplasmic ToxR domain is substituted only by a short leucine zipper peptide are not stably inserted into the inner membrane (Kolmar *et al.*, 1995a), we generated tripartite fusion proteins by placing the monomeric maltose-binding protein MalE between the transmembrane (ToxR') or cytoplasmic [ToxR'(ΔTM)] ToxR modules and the C-terminal leucine zipper peptides (Figure 2B). The ability of these ToxR chimeras to initiate transcription at the *ctx* promoter was then analyzed by measuring the β-galactosidase activity resulting from a chromosomal *ctx::lacZ* fusion in the *E. coli* reporter strain FHK12 (Kolmar *et al.*, 1995a) (Figure 2C). As a positive control for dimerization, we also re-analyzed the corresponding membrane-anchored and soluble GCN4 fusion proteins (Kolmar *et al.*, 1995a; Figure 2B and C). Finally, to allow a quantitative comparison of the transcriptional activities, we examined the stability and the cellular levels of the ToxR fusion proteins by immunoblotting (Figure 2D).

In accord with previous results (Kolmar *et al.*, 1995a), both the membrane-anchored and the soluble homodimerizing ToxR'MalEGCN and ToxR'(ΔTM)MalEGCN proteins exhibited 5–8-fold higher transcriptional activities than the ToxR'MalE and ToxR'(ΔTM)MalE proteins although present in the cells at comparable levels (Figure 2C and D). The latter proteins mediated β-galactosidase activity slightly above the background level (FHK12 in Figure 2C). Consistent with the ability of Fos and Jun to form heterodimers, the co-production of both the membrane-anchored ToxR'MalEFos/Jun and the soluble ToxR'(ΔTM)MalEFos/Jun proteins resulted in significant higher β-galactosidase activities than their separate production. Moreover, comparable β-galactosidase activities were obtained by producing the homodimerization-deficient ToxR-Jun^{L14F/L21H} proteins along with their corresponding ToxR-Fos partners, demonstrating that the ToxR-mediated transcriptional activation at *ctx* is not affected by ToxR-Jun/Jun homodimerization but results from the formation of ToxR-Fos/Jun heterodimers. Noteworthy, the separately produced soluble ToxR'(ΔTM)MalEJun and ToxR'(ΔTM)MalEJun^{L14F/L21H} proteins were hardly detectable in the cells (Figure 2D), most likely owing to their degradation by cytoplasmic proteases. The still detectable transcriptional activity of the soluble ToxR'(ΔTM)MalFos/Jun and ToxR'(ΔTM)MalFos/Jun^{L14F/L21H} heterodimers suggests that the Jun proteins are protected from degradation by their interaction with ToxR'(ΔTM)MalFos. However, cultures producing the homodimerization-deficient ToxR'(ΔTM)MalEJun^{L14F/L21H} protein together with ToxR'(ΔTM)MalEFos showed large variations in β-galactosidase activity (Figure 2C), suggesting that this ToxR variant is unstable even in presence of its interaction partner. Finally, while Jun has been reported to form homodimers in the absence of Fos (Smeal *et al.*, 1989), not even the membrane-anchored ToxR'MalEJun protein, which was present in the cells at levels comparable to ToxR'MalEGCN (Figure 2D), showed detectable transcriptional activity. Possibly higher cellular concentrations of ToxR'MalEJun are required to monitor its homodimerization. However, overall the above results demonstrate that the ToxR-system is applicable for the detection of heterodimerization in both the *E. coli* cytoplasm and periplasm.

DNA binding and transcriptional activation by ToxR

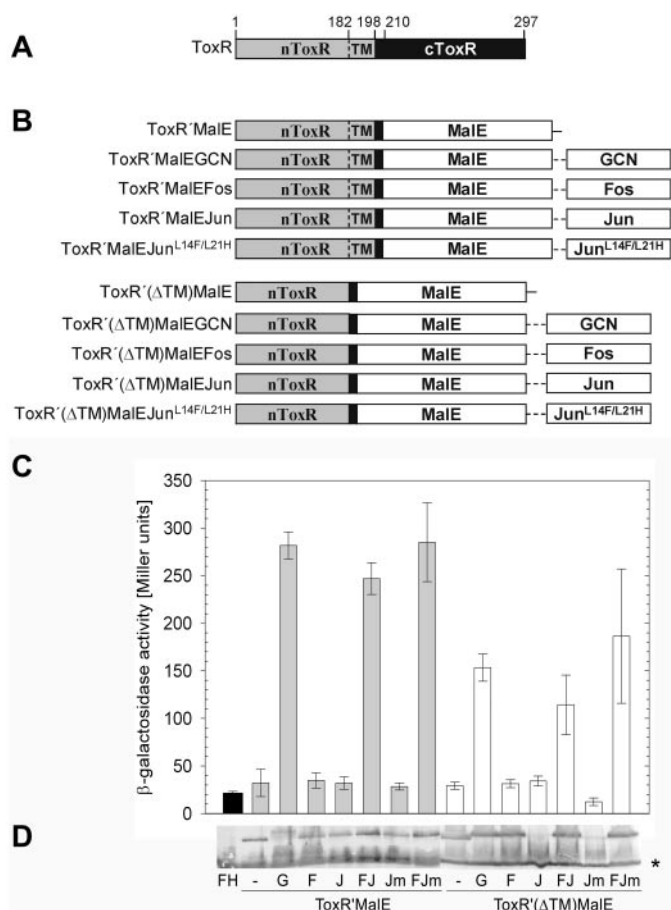

Fig. 2. Activity of membrane-anchored and soluble, homo- and heterodimerizing ToxR derivatives. (A) Modular organization of the *V. cholerae* signal transduction protein ToxR. Numbers indicate amino acid positions corresponding to Swiss-Prot accession number P15795. nToxR, N-terminal, cytoplasmic domain (amino acids 1–182); cToxR, C-terminal, periplasmic domain (amino acids 199–297); TM, transmembrane segment (amino acids 183–198). (B) Modular organization of chimeric ToxR proteins. Amino acids 1–210 of ToxR (termed ToxR') serve as the reference module in all membrane-anchored ToxR derivatives. Soluble ToxR derivatives were generated by deletion of the hydrophobic transmembrane segment and carry amino acids 1–182 plus amino acids 199–210 of the periplasmic ToxR domain (=region X, indicated by a black box) as the reference module [termed ToxR'(ΔTM)]. Linker peptides in ToxR-MalE derivatives originating from pMal-p are indicated by solid (10 amino acids, NSSVVPGRGS) and dashed lines (14 amino acids, NSSVVPGRGSIEGR), respectively. Fos, GCN, Jun, leucine zippers of the transcriptional activators Fos, GCN4 and Jun, respectively; Jun^{L14F/L21H}, homodimerization-deficient Jun mutant (Smeal *et al.*, 1989); MalE, maltose-binding protein. (C) Transcription activation at the *ctx* promoter in *E. coli* mediated by the ToxR derivatives shown in (B). Each bar represents the specific β-galactosidase activity in crude cell lysates of at least three independent overnight cultures. Standard deviations are indicated. Black bar, the plasmid-free reporter strain FHK12 (FH; negative control); gray bars, membrane-anchored ToxR variants; white bars, soluble, cytoplasmic ToxR variants. dash, no C-terminal leucine zipper; G, GCN; F, Fos; J, Jun; Jm, Jun^{L14F/L21H}. (D) Immunodetection of ToxR-MalE fusion proteins. Samples corresponding to 10⁸ cells were taken from the cultures analyzed in C and subjected to western blot analysis using MalE-specific antibodies. The periplasmic MalE protein serves as an internal control (indicated by an asterisk) to confirm loading of comparable sample sizes. While the ToxR'MalEGCN signal was somewhat weaker than the ToxR'MalEJun or ToxR'MalEFos signals only in this particular experiment, the protein ran with lower electrophoretic mobility in all experiments for unknown reasons.

The cytoplasmic DNA-binding domain of ToxR promotes oligomer formation in vitro

The soluble ToxR'(ΔTM)MalE and ToxR'(ΔTM)MalEGCN proteins and the corresponding variants lacking the MalE moiety, ToxR'(ΔTM) and ToxR'(ΔTM)GCN, respectively,

were purified and their apparent molecular weights determined by gel filtration to confirm their monomeric and dimeric states, respectively. The maltose-binding protein MalE and a MalE-GCN fusion protein, which forms homodimers with a K_D below 0.1 μM (Hope and Struhl, 1987; O'Shea *et al.*, 1989), served as monomeric and dimeric control proteins (Table II). The analysis confirmed a monomeric state of ToxR'(ΔTM)- ΔTM MalE and a dimeric state of ToxR'(ΔTM)MalEGCN. The ToxR'(ΔTM) and ToxR'(ΔTM)GCN proteins, however, revealed apparent M_r values that correspond to dimeric and pentameric states, respectively (Table II), suggesting that additional interaction sites may exist in the ToxR portion of the fusion proteins. In the ToxR'(ΔTM)MalE and ToxR'(ΔTM)MalEGCN proteins the voluminous MalE moiety may sterically hinder the association of these interaction sites.

The hinge region of ToxR is required for oligomer formation *in vitro* but not for activation of *ctx* transcription in *E.coli*

In the soluble ToxR fusion proteins, two regions are possible candidates for mediating the oligomerization that was observed *in vitro*. Firstly, the fusion proteins have been constructed in such a way that they retain a small portion of the C-terminal periplasmic domain of ToxR (Kolmar *et al.*, 1995a; amino acids 199–210 indicated by a black box in Figure 2B and Figure 3B and referred to as region X). The periplasmic domain, however, has been suggested to be important for the dimerization of ToxR *in vivo* (Dziejman and Mekalanos, 1994) and therefore it may be region X that is responsible for the *in vitro* oligomerization of the soluble ToxR fusion proteins. Alternatively, interaction sites responsible for oligomer formation may exist in the N-terminal cytoplasmic ToxR module. While its amino acids 20–123 show sequence similarity to the DNA binding/transcription activation wHTH domain of OmpR-like transcriptional activators (Martínez-Hackert and Stock, 1997; Krukoniš *et al.*, 2000) (Figure 3A), its amino acids 124–181 link the wHTH domain to the transmembrane segment (amino acids 182–198) of ToxR. This short hinge region is present in the soluble ToxR fusion proteins and might also mediate their oligomerization.

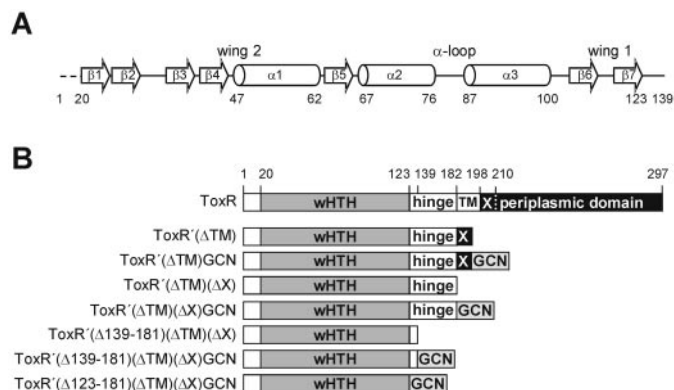

Fig. 3. Organization of the N-terminal, cytoplasmic DNA-binding domain of ToxR. (A) Predicted secondary structure of the wHTH motif in ToxR (according to Krukoniš *et al.*, 2000). Numbers indicate amino acid positions according to Swiss-Prot accession number P15795. (B) Modular organization of soluble ToxR deletion mutants. GCN, leucine zipper of the transcriptional activator GCN4; hinge, hinge region of ToxR; TM, transmembrane segment; X, region X (amino acids 199–210 of the periplasmic ToxR domain).

To determine whether or not these two regions, region X and the hinge region, play a role in ToxR activity and/or in oligomer formation, we generated variants of ToxR'(ΔTM) and ToxR'(ΔTM)GCN lacking region X [ToxR'(ΔTM)(ΔX) and ToxR'(ΔTM)(ΔX)GCN, Figure 3B] or lacking both region X and the hinge region [ToxR'($\Delta 124$ –181)(ΔTM)(ΔX)GCN, ToxR'($\Delta 139$ –181)(ΔTM)(ΔX) and ToxR'($\Delta 139$ –181)(ΔTM)(ΔX)GCN, Figure 3B] and investigated their ability to activate transcription at *ctx* in *E.coli* and to form oligomers *in vitro*. Whereas the region X deletion mutant ToxR'(ΔTM)(ΔX)GCN exhibited a transcriptional activity comparable to that of ToxR'(ΔTM)GCN (Figure 4), no transcriptional activity was detected for ToxR'($\Delta 124$ –181)(ΔTM)(ΔX)GCN, which lacked the complete hinge region (Figure 3B and data not shown). Furthermore, all attempts to purify the ToxR'($\Delta 124$ –181)(ΔTM)(ΔX)GCN protein failed (data not shown), suggesting that it was highly unstable. The ToxR'($\Delta 139$ –181)(ΔTM)(ΔX)GCN protein, in contrast, which still contains the first 16 amino acids of the hinge region (Figure 3B), mediated β -galactosidase activity just as well as ToxR'(ΔTM)GCN and ToxR'(ΔTM)(ΔX)GCN (Figure 4). Finally, the region X deletion mutant ToxR'(ΔTM)(ΔX) like ToxR'(ΔTM) showed no activity (Figure 4). Hence region X neither negatively nor positively affects the transcriptional activity of soluble ToxR proteins.

The analysis of the above proteins by gel filtration revealed that the region X deletion mutants ToxR'(ΔTM)(ΔX) and ToxR'(ΔTM)(ΔX)GCN are still able to form dimers and pentamers, respectively (Table II). This indicates that the presence of region X in the soluble ToxR derivatives is not responsible

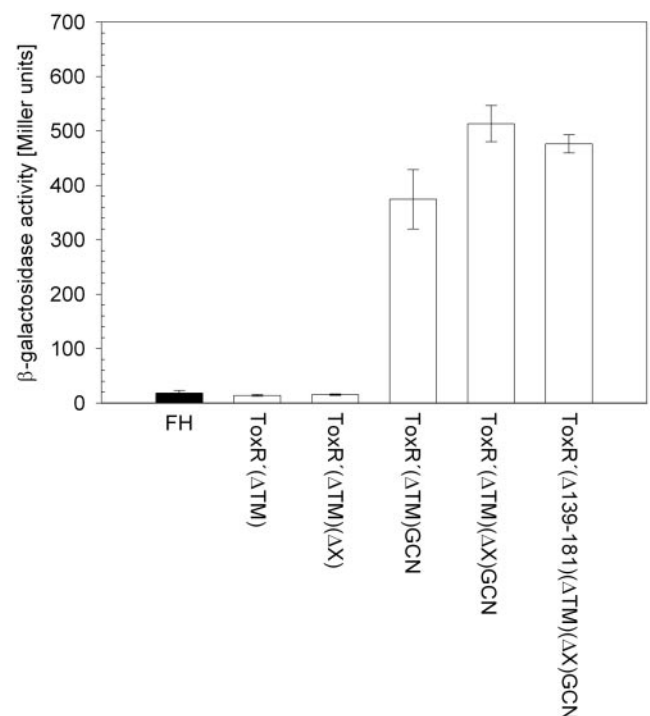

Fig. 4. Transcriptional activation at the *ctx* promoter in *E.coli* mediated by soluble region X and hinge region deletion mutants of ToxR. Each bar represents the specific β -galactosidase activity in crude cell lysates from at least three independent overnight cultures. Standard deviations are shown. Black bar, the plasmid-free reporter strain FHK 12 (FH, negative control). White bars, soluble, cytoplasmic ToxR proteins.

for their ability to oligomerize. In contrast, the apparent M_r values determined for the hinge region deletion mutants suggest a monomeric state of ToxR'(Δ 139–181)(Δ TM)(Δ X) and a dimeric/trimeric state of ToxR'(Δ 139–181)(Δ TM)(Δ X)GCN. We therefore suggest that the hinge region of ToxR (amino acids 139–181) is responsible for the ability of the cytoplasmic ToxR module to dimerize *in vitro* but is not required for ToxR-mediated transcriptional activation at *ctx* in *E. coli*.

Analysis of DNA binding by soluble ToxR derivatives

To study the requirements for specific DNA binding by ToxR we analyzed the interaction of ToxR'(Δ TM) and ToxR'(Δ TM)GCN with DNA in electrophoretic mobility shift assays (Figure 5) and by surface plasmon resonance (SPR) (Figure 6). For both experimental approaches, an about 200 bp *ctx* promoter fragment and an about 410 bp *hel* fragment were used as specific and non-specific DNA probes, respectively. The core sequence (138 bp) in the *ctx*

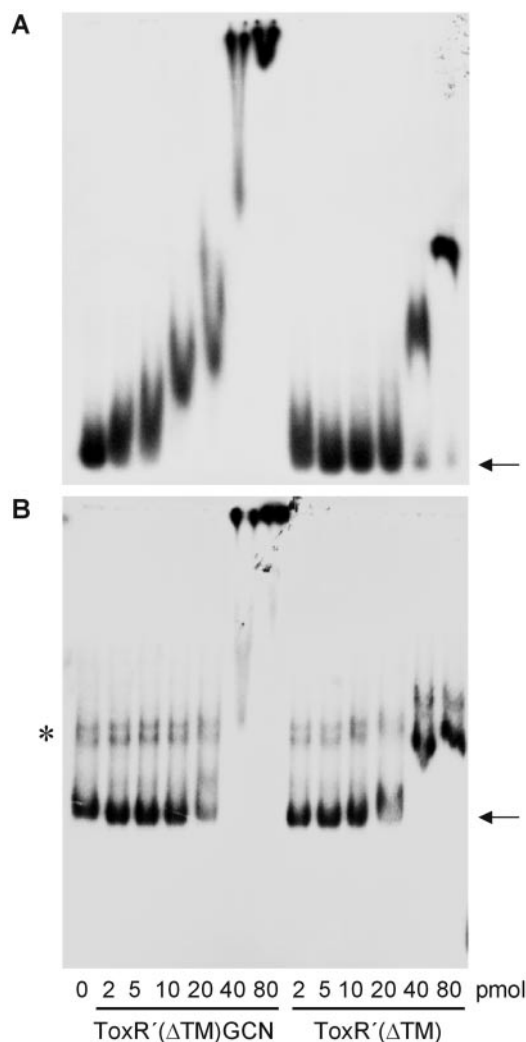

Fig. 5. Analysis of ToxR'(Δ TM) and ToxR'(Δ TM)GCN DNA binding by electrophoretic mobility shift assays. Radiolabeled (50 fmol) specific *ctx* promoter DNA (A) and non-specific *helE35Q*-DNA (B) were incubated with indicated amounts of ToxR'(Δ TM) and ToxR'(Δ TM)GCN in the presence of 500 ng of cold salmon sperm competitor DNA in a total volume of 50 μ l as described in Materials and methods and analyzed by non-denaturing polyacrylamide gel electrophoresis. Arrows indicate the free *ctx*- and *helE35Q*-DNA fragments. The asterisk marks DNA fragments of unknown identity present in some *hel*-DNA preparations.

fragment is identical with the chromosomal *ctx* promoter region in the *E. coli* reporter strain FHK12 (Kolmar *et al.*, 1995a) but, in contrast to the *ctx* promoter region of *V. cholerae* (Miller *et al.*, 1987; GenEMBL accession number 00171), carries an only 7-fold instead of an 8-fold direct repeat of the heptanucleotide sequence *TTTTGAT*. The flanking regions of *ctx* (~30 bp) originate from pMc vector DNA (see Supplementary data, 'Plasmid constructions'). The *hel*-DNA fragment corresponds to nucleotides 79–471 of GenBank accession number V00428, encoding mature hen egg lysozyme with a G to C mutation in codon 35 (*helE35Q*). The fragment is flanked on either side by eight base pairs originating from the primers used for its PCR amplification (see Supplementary data, 'Plasmid constructions').

In accord with the observed transcriptional activities *in vivo*, the mobility shift assays revealed that ToxR'(Δ TM)GCN binds to *ctx*-DNA with higher specificity than ToxR'(Δ TM) (Figure 5A). Under the given experimental conditions (see Materials and methods), first detectable interactions of ToxR'(Δ TM)GCN with *ctx* promoter DNA occurred at a protein:DNA ratio of 100:1 (Figure 5A, 5 pmol). Increasing protein amounts then resulted in further retardation of the protein–DNA complexes, until in the presence of ≥ 40 pmol of ToxR'(Δ TM)GCN high molecular weight aggregates with strongly reduced electrophoretic mobility were formed.

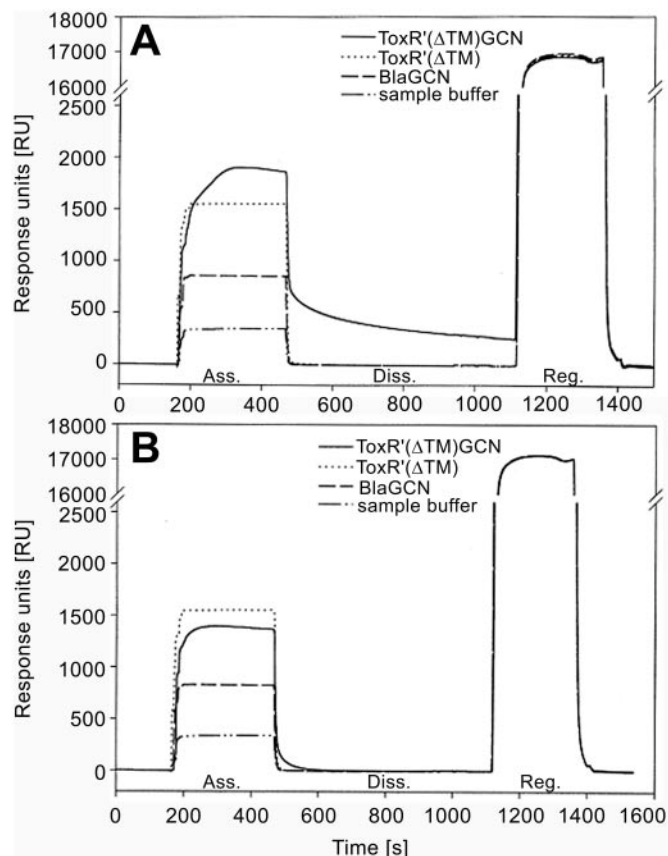

Fig. 6. Analysis of the interaction of ToxR'(Δ TM) and ToxR'(Δ TM)GCN with *ctx*- (A) and *hel*- (B) DNA by surface plasmon resonance. Biotinylated *ctx*- and *hel*-DNA-fragments were immobilized on an SA5 sensor chip surface at final densities of 2.1 and 1.0 fmol/mm², respectively, as described in Materials and methods. The indicated proteins (20 pmol) were passed over the DNA-functionalized sensor chip surfaces at constant flow rates of 2 μ l/min. Association (Ass.), dissociation (Diss.) and regeneration (Reg.) phases are indicated.

This shift mode suggests that the *ctx* fragment provides multiple binding sites for ToxR and that these binding sites are occupied by ToxR'(Δ TM)GCN successively in a concentration-dependent manner.

In contrast to ToxR'(Δ TM)GCN, eight times more protein (40 pmol) was required to observe complex formation between ToxR'(Δ TM) and *ctx*-DNA. At 40 pmol, however, both ToxR'(Δ TM) and ToxR'(Δ TM)GCN already interacted with the *helE35Q* control DNA (Figure 5B), ToxR'(Δ TM)GCN again forming high molecular weight aggregates. This suggests that these complexes rather reflect non-specific binding of the proteins to *ctx* and *hel* DNA, which might occur possibly because at higher protein concentrations all potential non-specific binding sites provided by the cold salmon sperm competitor DNA have been bound. Still, a further increase in protein concentration resulted in a further shift of ToxR'(Δ TM)-*ctx* complexes (Figure 5A) but not of ToxR'(Δ TM)-*helE35Q* complexes (Figure 6B), suggesting that ToxR'(Δ TM) exhibits higher binding specificity for *ctx*- than for *helE35Q*-DNA. Finally, the mobility shift patterns obtained for binding of the oligomerization-deficient ToxR'(Δ 139–181)(Δ TM)(Δ X)GCN protein to *ctx*- and *hel*-DNA were similar to those obtained for ToxR'(Δ TM)GCN Δ TM)GCN binding to these DNA fragments (data not shown and Figure 5). Hence the ability to form higher order oligomers is not required for specific DNA binding by ToxR dimers and does not affect the binding mode.

The interaction of ToxR'(Δ TM)GCN and ToxR'(Δ TM) with *ctx*- and *helE35Q*-DNA was also analyzed by SPR (Figure 6). The biotinylated DNA-fragments were immobilized on a streptavidin sensor chip as described in Materials and methods and the proteins (20 pmol in 10 μ l of sample buffer) passed over the chip surface at a constant flow rate of 2 μ l/min. Injection of ToxR'(Δ TM)GCN to the *ctx* chip resulted in a fast initial association phase that plateaued at about 2000 response units (RU), indicating that the protein rapidly bound to the *ctx* fragment until steady state (Figure 6A). ToxR'(Δ TM)GCN then dissociated in two phases. Unbound or loosely attached protein was washed off the surface in a first rapid dissociation phase, which was followed by a second, slow dissociation phase that started at \sim 750 RU and very slowly approached the baseline, indicative of a fairly strong interaction of ToxR'(Δ TM)GCN with the *ctx* fragment. In contrast, the sensorgram of ToxR'(Δ TM) binding to the *ctx* chip hardly differs from the buffer control in that a plateau was reached immediately upon injection, indicating that no or only little protein bound to the chip surface. Accordingly, dissociation occurred rapidly back to the baseline level. Hence ToxR'(Δ TM)GCN but not ToxR'(Δ TM) binds with high affinity to *ctx*, again suggesting dimerization as the critical parameter for specific ToxR–DNA interaction. To rule out the possibility that the ToxR'(Δ TM)GCN–DNA interaction was mediated by the GCN component, we also examined *ctx* binding by a BlaGCN fusion protein. As for ToxR'(Δ TM), the resulting sensorgram did not reveal any specific interaction of BlaGCN with the *ctx*-DNA chip surface. Hence the GCN component does not mediate DNA binding.

Finally, all three proteins showed very similar sensorgrams when passed over the *helE35Q*-DNA chip (Figure 6B). Their traces did not reveal any significant protein–DNA interactions and differed only in their signal heights. Only a very slight retardation in the dissociation of ToxR'(Δ TM)GCN from the

hel chip indicates that some non-specific ToxR'(Δ TM)GCN–*helE35Q* interactions might have occurred and appear to be even more stable than ToxR'(Δ TM)-*ctx* interactions.

Overall, the mobility shift and SPR data show that the cytoplasmic ToxR module ToxR'(Δ TM) binds DNA with only low specificity. In contrast, ToxR'(Δ TM)GCN exhibits strong specificity for *ctx*-DNA, corroborating the notion that dimerization is a prerequisite for efficient and specific DNA binding by ToxR.

Discussion

Even though the ToxR system offers the advantages of prokaryotic two-hybrid systems and, moreover, provides a broader potential application range than the systems described to date, it has not yet been widely implemented for protein–protein interaction studies. This may be due in part to the fact that the molecular basis of ToxR's function as a transcriptional activator of the *ctx* promoter in *E.coli* is still only poorly understood. We have investigated the minimal requirements for specific DNA binding and for *ctx* promoter activation by ToxR in *E.coli* and have extended the ToxR system to the study of protein heterodimerization. Our work contributes to the understanding of the structure–function relationship in ToxR as a prerequisite for the enhancement of ToxR's use as a prokaryotic two-hybrid system.

Requirements for specific DNA binding and transcriptional activation by ToxR

We have shown that the soluble ToxR'(Δ TM) and ToxR'(Δ TM)GCN proteins form dimers and higher order oligomers *in vitro*, respectively, suggesting that the N-terminal cytoplasmic ToxR module harbors previously unidentified interaction sites. We have confirmed that oligomerization is not mediated by a short fragment of the periplasmic ToxR domain (region X) present in all ToxR fusion proteins. The existence of additional interaction sites in the N-terminal DNA-binding module of ToxR has consequences for the applicability of ToxR as a genetic indicator for protein–protein interactions, since it might cause misleadingly high transcriptional activities particularly for ToxR fusion proteins with only weakly interacting C-terminal fusion partners. Therefore, we have identified the region in the N-terminal ToxR module responsible for *in vitro* oligomerization and asked whether this region affects ToxR function. Our data show that *in vitro* ToxR–ToxR interactions are mediated by a short hinge region, which in the full-length ToxR protein lies between the WHTH motif and the transmembrane segment (amino acids 139–181). The hinge region, however, is neither required for specific *ctx*-DNA binding *in vitro* nor for *ctx* promoter activation in *E.coli*, suggesting that the WHTH motif of the N-terminal ToxR domain in fusion with a dimerizing protein module is sufficient to activate transcription at *ctx* in *E.coli*. We have not yet tested whether the hinge region can also be deleted from membrane-anchored ToxR derivatives without loss of function. Possibly it confers flexibility on the N-terminal domain of membrane-anchored ToxR proteins that is required to allow its association into a functional dimeric state (see discussion below). Finally, the identification of the hinge region in ToxR's N-terminal domain as the site responsible for mediating ToxR–ToxR interactions may also be of biological relevance. Using a system that reports via

transcriptional activation of a P_{RM} -*lacZ* fusion, it has previously been shown that ToxR dimers are capable of interacting cooperatively and that these interactions are mediated by its cytoplasmic module (Dziejman *et al.*, 1999). Hence the hinge region would be a primary candidate for an interaction site that is responsible for these cooperative interactions. Although they may not be important for binding and activation of *ctx* (our data do not support a role of cooperative ToxR interactions in *ctx* binding and activation in *E.coli* and in *V.cholerae* the direct involvement of ToxR in *ctx* activation remains uncertain), they may still be relevant for the ToxR-mediated regulation of other ToxR-regulon genes in *V.cholerae*. Cooperative ToxR interactions have, for example, been suggested to play a role in the binding and activation of the *ompU* promoter (Crawford *et al.*, 1998).

One question that arises from our studies is why ToxR'(Δ TM) dimerizes *in vitro* but does not activate transcription at *ctx* *in vivo*. Our electrophoretic mobility shift assays show that the isolated cytoplasmic ToxR'(Δ TM) module in principle is capable of binding to DNA but that it acquires specificity for the *ctx* promoter sequence only in fusion with a dimerizing protein module (e.g. GCN4). Binding of ToxR'(Δ TM) to *ctx* required a protein concentration that also resulted in unspecific interactions with the *hel* control DNA (protein:DNA ratio of 800:1). In contrast, first ToxR'(Δ TM)GCN-*ctx* complexes were observed at a protein:DNA ratio of 100:1. Moreover, the ToxR'(Δ TM)GCN protein interacted more strongly with the *ctx* fragment than ToxR'(Δ TM), as indicated by its slow dissociation from *ctx* in SPR experiments. Hence the GCN-mediated dimerization of ToxR'(Δ TM) increases its DNA-binding specificity. Furthermore, ToxR'(Δ TM)GCN bound *ctx* in a concentration-dependent manner, suggesting the existence of multiple binding sites which are occupied successively by multiple ToxR molecules. The seven tandemly repeated copies of the *TTTTGAT* heptad in the *ctx* promoter fragment are primary candidates for such multiple ToxR binding sites. This would also be consistent with earlier observations that ToxR requires multiple *TTTTGAT* direct repeats upstream of the *ctxAB* structural genes for binding and that promoter activity as well as the apparent relative strength of the ToxR-*ctx* interaction increases with the number of repeats (Miller and Mekalanos, 1984; Miller *et al.*, 1987; Pfau and Taylor, 1996). Overall, we conclude that dimerization of ToxR'(Δ TM) and ToxR'(Δ TM)GCN involves different surfaces of the cytoplasmic ToxR module, such that the ToxR'(Δ TM)GCN but not the ToxR'(Δ TM) dimer is sterically qualified to interact specifically with the *ctx* promoter sequence. Finally, deletion of the hinge region from ToxR'(Δ TM)GCN did not affect its interaction with the *ctx* and *hel* fragments, indicating that the oligomerization of ToxR dimers does not alter their DNA-binding specificity and that oligomerization is not required for a rapid and complete occupation of *ctx* *in vitro*.

A ToxR-based prokaryotic two-hybrid system

Currently, two systems exist that use ToxR as a genetic indicator for folding stability (Kolmar *et al.*, 1995b) and for interactions between heterologous protein modules or membrane-spanning protein domains (Kolmar *et al.*, 1994, 1995a,b; Langosch *et al.*, 1996; Russ and Engelmann, 1999). Both systems are based on the original notion that the activity of ToxR as a transcriptional activator of *ctx* in *E.coli* depends

on the dimerization of its cytoplasmic DNA-binding domain (Miller *et al.*, 1987; DiRita and Mekalanos, 1991) and both take advantage of the finding that the periplasmic domain of ToxR and its transmembrane segment can be replaced individually by heterologous protein modules without loss of function. The ToxR system developed by Kolmar *et al.* (1994) and used in this study assays dimerization-induced *ctx* activation by monitoring β -galactosidase activity originating from a single chromosomal copy of the *ctx::lacZ* reporter fusion (*E.coli* strain FHK12). The various ToxR constructs are constitutively produced from a plasmid vector. Besides its applicability to study symmetric interactions of heterologous fusion partners in the periplasm of *E.coli*, this system has also been shown to be a useful tool for the detection of protein homodimerization in the *E.coli* cytoplasm (Kolmar *et al.*, 1994, 1995a). Using the leucine zippers Jun and Fos as model proteins for heterodimerization, we have shown here that the ToxR system also allows the detection of asymmetric protein interactions in both cellular compartments of *E.coli*. Consistent with similar association constants of 10^7 M^{-1} for GCN and for Jun/Fos, respectively (Blondel and Bedouelle, 1991; Pernelle *et al.*, 1993), the transcriptional activity of the co-produced membrane-anchored and soluble ToxR-Fos/Jun proteins was comparable to that of the respective homodimerizing ToxR-GCN fusion proteins. We were not able, however, to monitor Jun/Jun homodimerization even though at least the membrane-anchored ToxR'MalEJun protein was present in the cells at a level comparable to ToxR'MalEGCN. One possible explanation for this lack of detectable transcriptional activity may be a lower stability of Jun/Jun homodimers as compared with Fos/Jun heterodimers. Studies performed by Smeal *et al.* (1989) are in support of this assumption, although to our knowledge an association constant has not yet been determined for the Jun/Jun homodimer. However, the failure to measure ToxR'MalEJun-mediated transcriptional activation of *ctx* suggests that it may be lower than the detectable threshold value of the ToxR system. The determination of this threshold value would therefore be a valuable contribution to the enhancement of the ToxR system.

Another aspect of ToxR's technical utility is reflected in the TOXCAT assay, which was developed to study the association of transmembrane helices in a natural membrane environment (Russ and Engelmann, 1999). TOXCAT uses a plasmid-encoded *ctx:chloramphenicol acetyl transferase* (CAT) reporter fusion to measure *ctx* activation by quantifying chloramphenicol acetylation by CAT *in vitro* or by acquired resistance to chloramphenicol *in vivo*. The chimeric *toxR* genes are located on the same plasmid under control of a *lac* promoter to allow a modulation of their cellular concentration.

Overall, the ToxR system provides the advantages that *E.coli*-based two-hybrid systems have over the yeast two-hybrid system (for a review, see Hu *et al.*, 2000), but, by allowing the analysis of periplasmic and transmembrane protein-protein interactions, offers an even broader potential application range than the prokaryotic two-hybrid systems described to date (e.g. Hu *et al.*, 1990; Dove *et al.*, 1997; Dmitrova *et al.*, 1998; Karimova *et al.*, 1998; Di Lallo *et al.*, 2001). Moreover, the option to study interactions in the periplasm of *E.coli* provides a promising basis for the expansion of the ToxR system towards screening of low molecular weight compounds to study ligand-binding or ligand-induced conformational changes, since it obviates the necessity for such

compounds supplied externally with the *E.coli* growth medium to pass the cytoplasmic membrane. In this context, the ToxR system could furthermore be adjusted for high-throughput screening by converting it into a mating-based, conjugative system, as has recently been described for the LexA-based prokaryotic two-hybrid system (Clarke *et al.*, 2005).

Acknowledgements

We thank T.Hartsch for the gift of BlaGCN fusion protein and for help with SPR experiments and H.-J.Fritz, W.Kramer and H.Kolmar for helpful discussions and comments.

References

- Blondel,A. and Bedouelle,H. (1991) *Protein Eng.*, **4**, 457–461.
- Clarke,P., Ó Cuív,P. and O’Connell,M. (2005) *Nucleic Acids Res.*, **33**, e18.
- Crawford,J.A., Kaper,J.B. and DiRita,V.J. (1998) *Mol. Microbiol.*, **29**, 235–246.
- Di Lallo G., Castagnoli,L., Ghelardini,P. and Paolozzi,L. (2001) *Microbiology*, **147**, 1651–1656.
- DiRita,V.J. and Mekalanos,J.J. (1991) *Cell*, **64**, 29–37.
- DiRita,V.J., Parsot,C., Jander,G. and Mekalanos,J.J. (1991) *Proc. Natl Acad. Sci. USA*, **88**, 5403–5407.
- Dmitrova,M., Younès-Cauet,G., Oertel-Buchheit,P., Porte,D., Schnarr,M. and Granger-Schnarr,M. (1998) *Mol. Gen. Genet.*, **257**, 205–212.
- Dove,S.L., Joung,J. and Hochschild,A. (1997) *Nature*, **386**, 627–630.
- Duplay,P., Szmelcman,S., Bedouelle,H. and Hofnung,M. (1987) *J. Mol. Biol.*, **194**, 663–673.
- Dziejman,M. and Mekalanos,J.J. (1994) *Mol. Microbiol.*, **13**, 485–494.
- Dziejman,M., Kolmar,H., Fritz,H.-J. and Mekalanos,J.J. (1999) *Mol. Microbiol.*, **31**, 305–317.
- Higgins,D.E., Nazareno,E. and DiRita,V.J. (1992) *J. Bacteriol.*, **174**, 6974–6980.
- Hope,I.A. and Struhl,K. (1987) *EMBO J.*, **6**, 2781–2784.
- Hu,J.C., O’Shea,E.K., Kim,P.S. and Sauer,R.T. (1990) *Science*, **250**, 1400–1403.
- Hu,J.C., Kornacker,M.G. and Hochschild,A. (2000) *Methods*, **20**, 80–94.
- Karimova,G., Pidoux,J., Ullmann,A. and Ladant,D. (1998) *Proc. Natl Acad. Sci. USA*, **95**, 5752–5756.
- Kolmar,H., Frisch,C., Kleemann,G., Götze,K., Stevens,F.J. and Fritz,H.-J. (1994) *Biol. Chem. Hoppe-Seyler*, **375**, 61–70.
- Kolmar,H., Hennecke,F., Götze,K., Janzer,B., Vogt,B., Mayer,F. and Fritz,H.-J. (1995a) *EMBO J.*, **14**, 3895–3904.
- Kolmar,H., Frisch,C., Götze,K. and Fritz,H.-J. (1995b) *J. Mol. Biol.*, **251**, 471–476.
- Krukonis, E.S., Yu,R.R. and DiRita,V.J. (2000) *Mol. Microbiol.*, **38**, 67–84.
- Langosch,D., Brosig,B., Kolmar,H. and Fritz,H.-J. (1996) *J. Mol. Biol.*, **263**, 525–530.
- Martínez-Hackert,E. and Stock,A.M. (1997) *J. Mol. Biol.*, **296**, 301–312.
- Miller,V.L. and Mekalanos,J.J. (1984) *Proc. Natl Acad. Sci. USA*, **81**, 3471–3475.
- Miller,V.L., Taylor,R.K. and Mekalanos,J.J. (1987) *Cell*, **48**, 271–279.
- O’Shea,E.K., Rutkowski,R., Stafford,W.F.,III and Kim,P.S. (1989) *Science*, **245**, 646–648.
- Pace,C.N., Vajdos,F., Fee,L., Grimsley,G. and Gray,T. (1995) *Protein Sci.*, **4**, 2411–2423.
- Pernelle,C., Clerc,F.F., Dureuil,C., Bracco,L. and Tocque,B. (1993) *Biochemistry*, **32**, 11682–11687.
- Pfau,J.D. and Taylor,R.K. (1996) *Mol. Microbiol.*, **20**, 213–222.
- Russ,W.P. and Engelman,D.M. (1999) *Proc. Natl Acad. Sci. USA*, **96**, 863–868.
- Sambrook,J., Fritsch,E. and Maniatis,T. (1989) *Molecular Cloning. A Laboratory Manual*. Cold Spring Harbor Laboratory Press, Cold Spring Harbor, NY.
- Shuman,H.A. (1982) *J. Biol. Chem.*, **257**, 5455–5461.
- Skerra,A. (1994) *Gene*, **151**, 131–135.
- Smeal,T., Angel,P., Meek,J. and Karin,M. (1989) *Genes Dev.*, **3**, 2091–2100.

Received May 6, 2005; revised July 19, 2005; accepted July 22, 2005

Edited by Marius Clore